

## Features

- Multiturn / Cermet / Industrial / Sealed
- 5 terminal styles
- Tape and reel packaging available
- Chevron seal design
- Listed on the QPL for style RJ24 per MIL-R-22097 and RJ24 per High-Rel Mil-R-39035

# 3296 - 3/8" Square Trimming Potentiometer

### Electrical Characteristics

Standard Resistance Range .....10 to 5 megohms  
(see standard resistance table)  
Resistance Tolerance .....±10% std.  
(tighter tolerance available)  
Absolute Minimum Resistance .....1% or 2 ohms max.  
(whichever is greater)  
Contact Resistance Variation .....1.0% or 3 ohms max.  
(whichever is greater)  
Adjustability  
Voltage .....±0.01%  
Resistance .....±0.05%  
Resolution .....Infinite  
Insulation Resistance .....500 vdc.  
1,000 megohms min.  
Dielectric Strength  
Sea Level .....900 vac  
70,000 Feet .....350 vac  
Effective Travel .....25 turns nom.

### Environmental Characteristics

Power Rating (300 volts max.)  
70°C .....0.5 watt  
125°C .....0 watt  
Temperature Range .....-55°C to +150°C  
Temperature Coefficient .....±100ppm/°C  
Seal Test .....85°C Fluorinert\*  
Humidity .....MIL-STD-202 Method 103  
96 hours  
(2% ΔTR, 10 Megohms IR)  
Vibration .....20G (1% ΔTR; 1% ΔVR)  
Shock .....100G (1% ΔTR; 1% ΔVR)  
Load Life .....1,000 hours 0.5 watt @ 70°C  
(3% ΔTR; 3% or 3 ohms, whichever is greater, CRV)  
Rotational Life .....200 cycles  
(4% ΔTR; 3% or 3 ohms, whichever is greater, CRV)

### Physical Characteristics

Torque .....3.0 oz-in. max.  
Mechanical Stops .....Wiper idles  
Terminals .....Solderable pins  
Weight .....0.03 oz.  
Marking .....Manufacturer's trademark, resistance code, wiring diagram, date code, manufacturer's model number and style  
Wiper .....Positioned at 50% nominal  
Flammability .....U.L. 94V-0  
Standard Packaging .....50 pcs. per tube  
Adjustment Tool .....H-90

\*"FLUORINERT" IS A REGISTERED TRADEMARK OF 3M CO.

### Common Dimensions

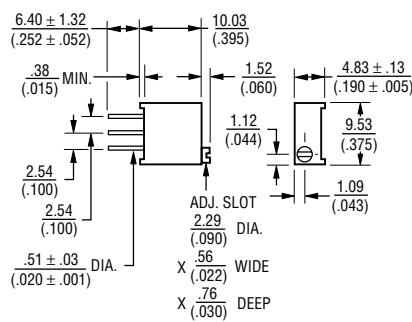

### 3296P

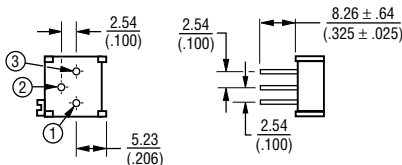

### 3296W

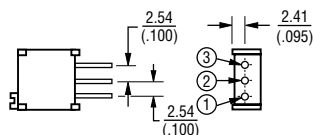

### 3296X

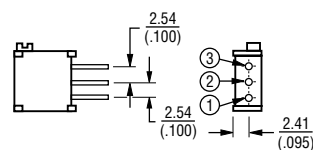

### How To Order

**3296 W - 1 - 103**  
 Model \_\_\_\_\_  
 Style \_\_\_\_\_  
 Standard or Modified Product Indicator \_\_\_\_\_  
 -1 = Standard Product  
 Resistance Code \_\_\_\_\_

Consult factory for other available options.

### 3296Y (Commercial Only)

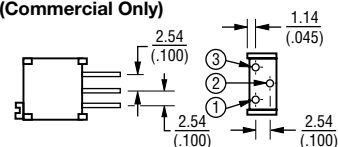

### 3296Z (Commercial Only)

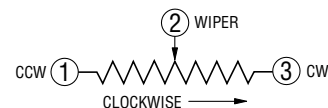
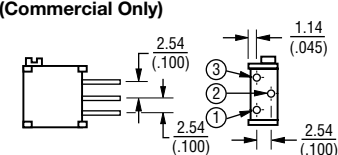

TOLERANCES: ± 0.25 (.010) EXCEPT WHERE NOTED

DIMENSIONS ARE:  $\frac{\text{METRIC}}{\text{(INCHES)}}$

### Standard Resistance Table

Resistance (Ohms)	Resistance Code
10	100
20	200
50	500
100	101
200	201
500	501
1,000	102
2,000	202
5,000	502
10,000	103
20,000	203
25,000	253
50,000	503
100,000	104
200,000	204
250,000	254
500,000	504
1,000,000	105
2,000,000	205

Popular values listed in boldface. Special resistances available.