



November 2014



# KSP2907A PNP General-Purpose Amplifier

## Features

- Collector-Emitter Voltage:  $V_{CEO} = -60\text{ V}$
- Suffix “-C” means a Center Collector (1. Emitter 2. Collector 3. Base)
- Non suffix “-C” means a Side Collector (1. Emitter 2. Base 3. Collector)
- Available as PN2907A

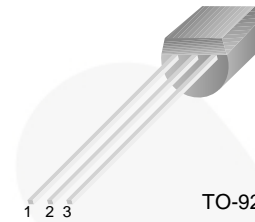

TO-92  
 KSP2907A: 1. Emitter 2. Base 3. Collector  
 KSP2907AC: 1. Emitter 2. Collector 3. Base

## Ordering Information<sup>(1)</sup>

Part Number	Marking	Package	Packing Method
KSP2907ABU	KSP2907A	TO-92 3L	Bulk
KSP2907ABU	KSP2907A	TO-92 3L	Ammo
KSP2907ATF	KSP2907A	TO-92 3L	Tape and Reel
KSP2907ACTA	KSP2907AC	TO-92 3L	Ammo

### Note:

1. Affix “-C-” means center collector pin. Suffix “-BU” means bulk packing, and straight lead form. Suffix “-TF” means tape & reel packing, and 0.200 in-line spacing lead form. Suffix “-TA” means ammo packing, and 0.200 in-line spacing lead form.

## Absolute Maximum Ratings

Stresses exceeding the absolute maximum ratings may damage the device. The device may not function or be operable above the recommended operating conditions and stressing the parts to these levels is not recommended. In addition, extended exposure to stresses above the recommended operating conditions may affect device reliability. The absolute maximum ratings are stress ratings only. Values are at  $T_A = 25^\circ\text{C}$  unless otherwise noted.

Symbol	Parameter	Value	Unit
$V_{CBO}$	Collector-Base Voltage	-60	V
$V_{CEO}$	Collector-Emitter Voltage	-60	V
$V_{EBO}$	Emitter-Base Voltage	-5	V
$I_C$	Collector Current	-600	mA
$T_J$	Junction Temperature	150	$^\circ\text{C}$
$T_{STG}$	Storage Temperature	-55 to +150	$^\circ\text{C}$

## Thermal Characteristics

Values are at  $T_A = 25^\circ\text{C}$  unless otherwise noted.

Symbol	Parameter	Max.	Unit
$P_D$	Power Dissipation by $R_{\theta JA}$	625	mW
	Derate Above $25^\circ\text{C}$	5	mW/ $^\circ\text{C}$
$R_{\theta JC}$	Thermal Resistance, Junction-to-Case <sup>(2)</sup>	83.3	$^\circ\text{C}/\text{W}$
$R_{\theta JA}$	Thermal Resistance, Junction-to-Ambient <sup>(3)</sup>	200	$^\circ\text{C}/\text{W}$

### Notes:

- Infinite heat sink.
- Minimum Land pad size.

## Electrical Characteristics<sup>(4)</sup>

Values are at  $T_A = 25^\circ\text{C}$  unless otherwise noted.

Symbol	Parameter	Conditions	Min.	Max.	Unit
$BV_{CBO}$	Collector-Base Breakdown Voltage	$I_C = -10 \mu\text{A}$ , $I_E = 0$	-60		V
$BV_{CEO}$	Collector-Emitter Breakdown Voltage	$I_C = -10 \text{mA}$ , $I_B = 0$	-60		V
$BV_{EBO}$	Emitter-Base Breakdown Voltage	$I_E = -10 \mu\text{A}$ , $I_C = 0$	-5.0		V
$I_{CBO}$	Collector Cut-Off Current	$V_{CB} = -50 \text{V}$ , $I_E = 0$		-10	nA
$h_{FE}$	DC Current Gain	$V_{CE} = -10 \text{V}$ , $I_C = -0.1 \text{mA}$	75		
		$V_{CE} = -10 \text{V}$ , $I_C = -1 \text{mA}$	100		
		$V_{CE} = -10 \text{V}$ , $I_C = -10 \text{mA}$	100		
		$V_{CE} = -10 \text{V}$ , $I_C = -150 \text{mA}$	100	300	
		$V_{CE} = -10 \text{V}$ , $I_C = -500 \text{mA}$	50		
$V_{CE(sat)}$	Collector-Emitter Saturation Voltage	$I_C = -150 \text{mA}$ , $I_B = -15 \text{mA}$		-0.4	V
		$I_C = -500 \text{mA}$ , $I_B = -50 \text{mA}$		-1.6	
$V_{BE(sat)}$	Base-Emitter Saturation Voltage	$I_C = -150 \text{mA}$ , $I_B = -15 \text{mA}$		-1.3	V
		$I_C = -500 \text{mA}$ , $I_B = -50 \text{mA}$		-2.6	
$C_{obo}$	Output Capacitance	$V_{CB} = -10 \text{V}$ , $I_E = 0$ , $f = 1.0 \text{MHz}$		8	pF
$f_T$	Current Gain Bandwidth Product	$I_C = -50 \text{mA}$ , $V_{CE} = -20 \text{V}$ , $f = 100 \text{MHz}$	200		MHz
$t_{ON}$	Turn-On Time	$V_{CC} = -30 \text{V}$ , $I_C = -150 \text{mA}$ , $I_{B1} = -15 \text{mA}$		45	ns
$t_{OFF}$	Turn-Off Time	$V_{CC} = -6 \text{V}$ , $I_C = -150 \text{mA}$ , $I_{B1} = I_{B2} = -15 \text{mA}$		100	ns

### Note:

- DC items are tested by pulse test: pulse width  $\leq 300 \mu\text{s}$ , duty cycle  $\leq 2\%$

## Typical Performance Characteristics

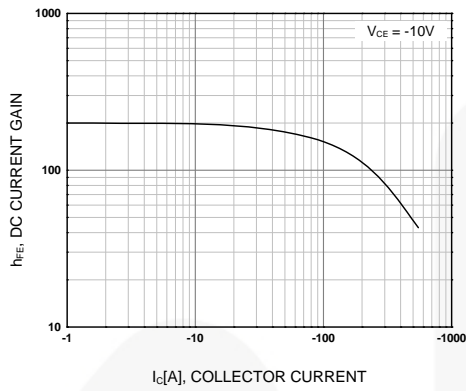

Figure 1. DC Current Gain

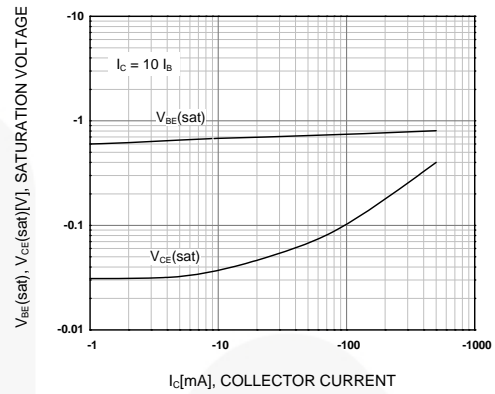

Figure 2. Collector-Emitter Saturation Voltage and Base-Emitter Saturation Voltage

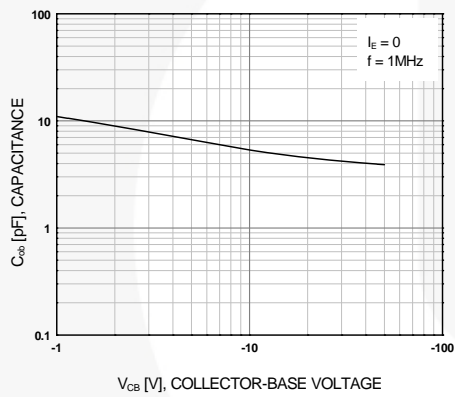

Figure 3. Output Capacitance

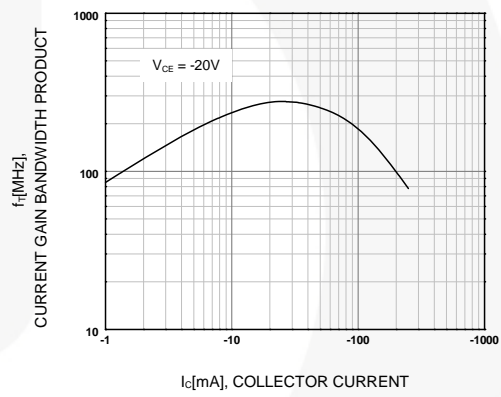
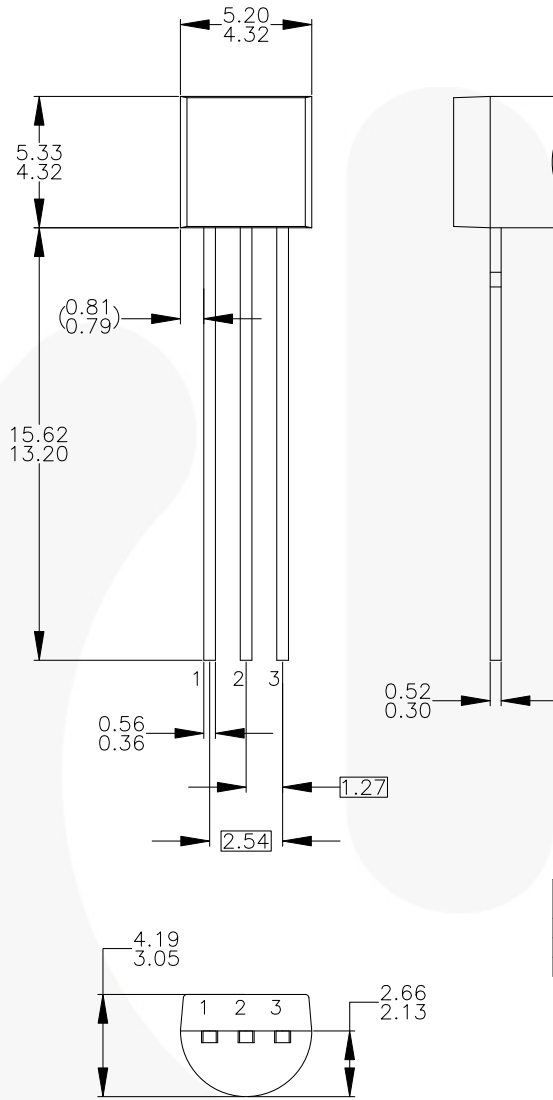

Figure 4. Current Gain Bandwidth Product

Physical Dimensions



NOTES: UNLESS OTHERWISE SPECIFIED

- A) DRAWING WITH REFERENCE TO JEDEC TO-92 RECOMMENDATIONS.
- B) ALL DIMENSIONS ARE IN MILLIMETERS.
- C) DRAWING CONFORMS TO ASME Y14.5M-1994.
- D) TO-92 (92,94,96,97,98) PIN CONFIGURATION:

PIN	92			94			96			97			98		
	P	F	M	P	F	M	B	F	M	P	F	M	P	F	M
1	E	S	S	E	S	S	B	D	G	C	G	D	C	G	D
2	B	D	G	C	G	D	E	S	S	B	D	G	E	S	S
3	C	G	D	B	D	G	C	G	D	E	S	S	B	D	G

LEGEND:

- P - BIPOLAR
- F - JFET
- M - DMOS
- E - EMITTER
- B - BASE
- C - COLLECTOR
- D - DRAIN
- S - SOURCE
- G - GATE

- E) FOR PACKAGE 92, 94, 96, 97 AND 98: PIN CONFIGURATION DRAIN "D" AND SOURCE "S" ARE INTERCHANGEABLE AT JFET "F" OPTION.
- F) DRAWING FILENAME: MKT-ZA03DREV3.

Figure 5. 3-Lead, TO-92, JEDEC TO-92 Compliant Straight Lead Configuration, Bulk Type

Physical Dimensions (Continued)

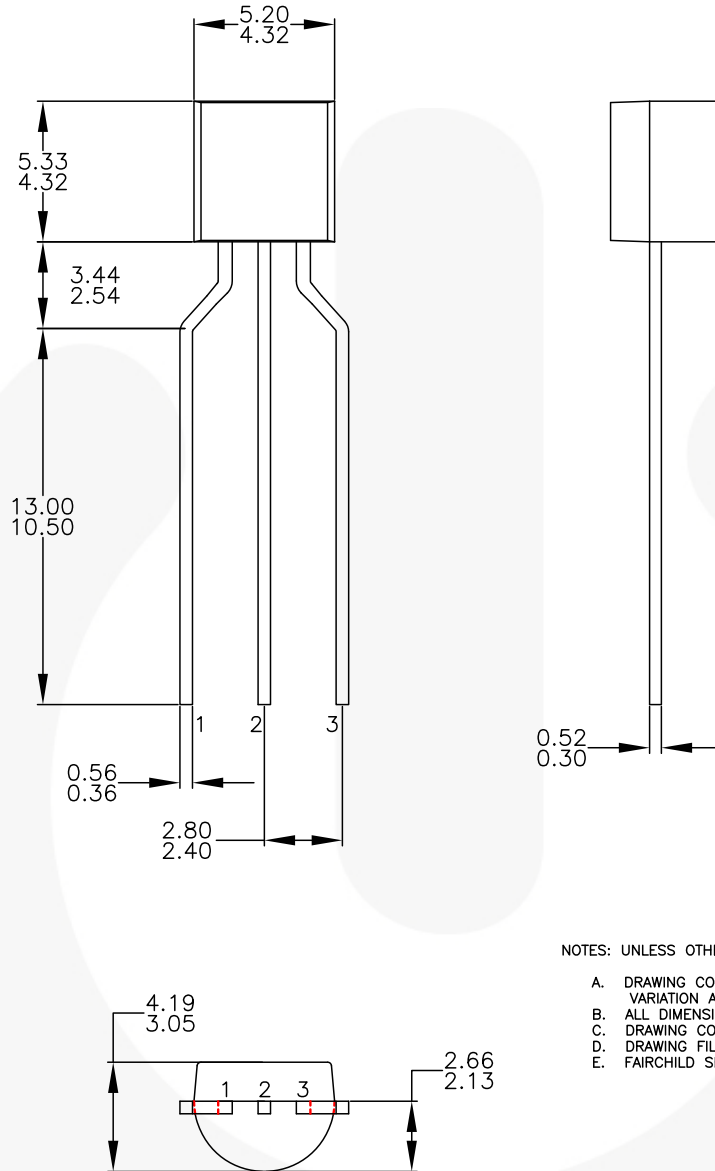

Figure 6. 3-Lead, TO-92, Molded, 0.2 In Line Spacing Lead Form, Ammo, Tape and Reel Type



**TRADEMARKS**

The following includes registered and unregistered trademarks and service marks, owned by Fairchild Semiconductor and/or its global subsidiaries, and is not intended to be an exhaustive list of all such trademarks.

- AccuPower™
- Awinda®
- AX-CAP®\*
- BitSiC™
- Build it Now™
- CorePLUS™
- CorePOWER™
- CROSSVOLT™
- CTL™
- Current Transfer Logic™
- DEUXPEED®
- Dual Cool™
- EcoSPARK®
- EfficientMax™
- ESBC™
- F**®
- Fairchild®
- Fairchild Semiconductor®
- FACT Quiet Series™
- FACT®
- FAST®
- FastvCore™
- FETBench™
- FPS™
- F-PFS™
- FRFET®
- Global Power Resource<sup>SM</sup>
- GreenBridge™
- Green FPS™
- Green FPS™ e-Series™
- Gmax™
- GTO™
- IntelliMAX™
- ISOPLANAR™
- Making Small Speakers Sound Louder and Better™
- MegaBuck™
- MICROCOUPLER™
- MicroFET™
- MicroPak™
- MicroPak2™
- MillerDrive™
- MotionMax™
- MotionGrid®
- MT<sup>+</sup>®
- MTx®
- MVN®
- mWSaver®
- OptoHiT™
- OPTOLOGIC®
- OPTOPLANAR®
- ®
- PowerTrench®
- PowerXS™
- Programmable Active Droop™
- QFET®
- QS™
- Quiet Series™
- RapidConfigure™
- ™
- Saving our world, 1mW/W/kW at a time™
- SignalWise™
- SmartMax™
- SMART START™
- Solutions for Your Success™
- SPM®
- STEALTH™
- SuperFET®
- SuperSOT™-3
- SuperSOT™-6
- SuperSOT™-8
- SupreMOS®
- SyncFET™
- Sync-Lock™
- SYSTEM GENERAL®
- TinyBoost®
- TinyBuck®
- TinyCalc™
- TinyLogic®
- TINYOPTO™
- TinyPower™
- TinyPWM™
- TinyWire™
- TranSiC™
- TriFault Detect™
- TRUECURRENT®\*
- µSerDes™
- SerDes™
- UHC®
- Ultra FRFET™
- UniFET™
- VCX™
- VisualMax™
- VoltagePlus™
- XS™
- Xsens™
- 仙童™

\* Trademarks of System General Corporation, used under license by Fairchild Semiconductor.

**DISCLAIMER**

FAIRCHILD SEMICONDUCTOR RESERVES THE RIGHT TO MAKE CHANGES WITHOUT FURTHER NOTICE TO ANY PRODUCTS HEREIN TO IMPROVE RELIABILITY, FUNCTION, OR DESIGN. TO OBTAIN THE LATEST, MOST UP-TO-DATE DATASHEET AND PRODUCT INFORMATION, VISIT OUR WEBSITE AT [HTTP://WWW.FAIRCHILDSEMI.COM](http://www.fairchildsemi.com). FAIRCHILD DOES NOT ASSUME ANY LIABILITY ARISING OUT OF THE APPLICATION OR USE OF ANY PRODUCT OR CIRCUIT DESCRIBED HEREIN; NEITHER DOES IT CONVEY ANY LICENSE UNDER ITS PATENT RIGHTS, NOR THE RIGHTS OF OTHERS. THESE SPECIFICATIONS DO NOT EXPAND THE TERMS OF FAIRCHILD'S WORLDWIDE TERMS AND CONDITIONS, SPECIFICALLY THE WARRANTY THEREIN, WHICH COVERS THESE PRODUCTS.

**LIFE SUPPORT POLICY**

FAIRCHILD'S PRODUCTS ARE NOT AUTHORIZED FOR USE AS CRITICAL COMPONENTS IN LIFE SUPPORT DEVICES OR SYSTEMS WITHOUT THE EXPRESS WRITTEN APPROVAL OF FAIRCHILD SEMICONDUCTOR CORPORATION.

As used herein:

1. Life support devices or systems are devices or systems which, (a) are intended for surgical implant into the body or (b) support or sustain life, and (c) whose failure to perform when properly used in accordance with instructions for use provided in the labeling, can be reasonably expected to result in a significant injury of the user.
2. A critical component in any component of a life support, device, or system whose failure to perform can be reasonably expected to cause the failure of the life support device or system, or to affect its safety or effectiveness.

**ANTI-COUNTERFEITING POLICY**

Fairchild Semiconductor Corporation's Anti-Counterfeiting Policy. Fairchild's Anti-Counterfeiting Policy is also stated on our external website, [www.fairchildsemi.com](http://www.fairchildsemi.com), under Sales Support.

Counterfeiting of semiconductor parts is a growing problem in the industry. All manufacturers of semiconductor products are experiencing counterfeiting of their parts. Customers who inadvertently purchase counterfeit parts experience many problems such as loss of brand reputation, substandard performance, failed applications, and increased cost of production and manufacturing delays. Fairchild is taking strong measures to protect ourselves and our customers from the proliferation of counterfeit parts. Fairchild strongly encourages customers to purchase Fairchild parts either directly from Fairchild or from Authorized Fairchild Distributors who are listed by country on our web page cited above. Products customers buy either from Fairchild directly or from Authorized Fairchild Distributors are genuine parts, have full traceability, meet Fairchild's quality standards for handling and storage and provide access to Fairchild's full range of up-to-date technical and product information. Fairchild and our Authorized Distributors will stand behind all warranties and will appropriately address any warranty issues that may arise. Fairchild will not provide any warranty coverage or other assistance for parts bought from Unauthorized Sources. Fairchild is committed to combat this global problem and encourage our customers to do their part in stopping this practice by buying direct or from authorized distributors.

**PRODUCT STATUS DEFINITIONS**

**Definition of Terms**

Datasheet Identification	Product Status	Definition
Advance Information	Formative / In Design	Datasheet contains the design specifications for product development. Specifications may change in any manner without notice.
Preliminary	First Production	Datasheet contains preliminary data; supplementary data will be published at a later date. Fairchild Semiconductor reserves the right to make changes at any time without notice to improve design.
No Identification Needed	Full Production	Datasheet contains final specifications. Fairchild Semiconductor reserves the right to make changes at any time without notice to improve the design.
Obsolete	Not In Production	Datasheet contains specifications on a product that is discontinued by Fairchild Semiconductor. The datasheet is for reference information only.

Rev. I72