

FEATURES

- **HIGH ISOLATION VOLTAGE**
BV: $5kV_{r.m.s.}$ MIN
- **HIGH COLLECTOR TO EMITTER VOLTAGE**
 V_{CE0} : 80 V MIN
- **HIGH CURRENT TRANSFER RATIO**
CTR: 300% TYP
- **HIGH SPEED SWITCHING**
 $t_r = 3 \mu s$, $t_f = 5 \mu s$ TYP
- **LOW COST**
- **ISOLATED CHANNELS PER EACH PACKAGE**

DESCRIPTION

NEC's PS2501-1, -2, -4 and PS2501L-1, -2, -4 are optically coupled isolators containing a GaAs light emitting diode and an NPN silicon phototransistor. PS2501-1, -2, -4 are in a plastic DIP (Dual In-line Package) and PS2501L-1, -2, -4 are lead bending type (Gull-wing) for surface mount.

APPLICATIONS

Interface circuit for various instrumentations and control equipments

- AC LINE / DIGITAL LOGIC
- DIGITAL LOGIC / DIGITAL LOGIC
- TWISTED PAIR LINE RECEIVER
- TELEPHONE / TELEGRAPH LINE RECEIVER
- HIGH FREQUENCY POWER SUPPLY FEEDBACK CONTROL
- RELAY CONTACT MONITOR
- POWER SUPPLY MONITOR

ELECTRICAL CHARACTERISTICS ($T_A = 25^\circ C$)

PART NUMBER			PS2501-1, -2, -4 PS2501L-1, -2, -4			
	SYMBOLS	PARAMETERS	UNITS	MIN	TYP	MAX
Diode	V_F	Forward Voltage, $I_F = 10$ mA	V		1.17	1.4
	I_R	Reverse Current, $V_R = 5$ V	μA			5
	C	Junction Capacitance, $V = 0$, $f = 1.0$ MHz	pF		50	
Transistor	I_{CEO}	Collector to Emitter Dark Current, $V_{ce} = 80$ V, $I_F = 0$	nA			100
Coupled	CTR	Current Transfer Ratio ¹ , $I_F = 5$ mA, $V_{CE} = 5$ V	%	80	300	600
	$V_{CE(sat)}$	Collector Saturation Voltage, $I_F = 10$ mA, $I_C = 2$ mA	V			0.3
	R1-2	Isolation Resistance, $V_{IN-OUT} = 1.0$ kV	Ω	10^{11}		
	C1-2	Isolation Capacitance, $V = 0$, $f = 1.0$ MHz	pF		0.5	
	t_r	Rise Time ² , $V_{CC} = 10$ V, $I_C = 2$ mA, $R_L = 100 \Omega$	μs		3	
	t_f	Fall Time ² , $V_{CC} = 10$ V, $I_C = 2$ mA, $R_L = 100 \Omega$	μs		5	

Notes:

1. CTR rank (PS2501-1, PS2501L-1 only)
2. Test Circuit for Switching
 K: 300 to 600 %
 L: 200 to 400 %
 M: 80 to 240 %
 D: 100 to 300 %
 H: 80 to 160 %
 W: 130 to 260 %
 Q: 100 to 200%
 N: 80 to 600 %

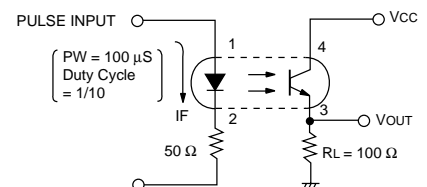
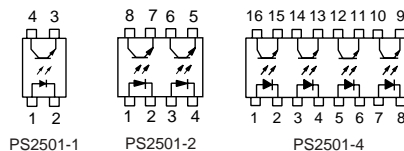

ABSOLUTE MAXIMUM RATINGS¹ (T_A = 25°C)

SYMBOLS	PARAMETERS	UNITS	RATINGS	
			PS2501-1 PS2501L-1	PS2501-2,4 PS2501L-2, 4
Diode				
I _F	Forward Current	mA	80	80
V _R	Reverse Voltage	V	6	6
ΔP _D /°C	Power Dissipation Derating	mW/°C	1.5	1.2
P _D	Power Dissipation	mW/Ch	150	120
I _F (PEAK)	Peak Forward Current (P _W = 100 μs, Duty Cycle 1%)	A	1	1
Transistor				
V _{CEO}	Collector to Emitter Voltage	V	80	80
V _{ECO}	Emitter to Collector Voltage	V	7	7
I _c	Collector Current	mA	50	50
ΔP _C /°C	Power Dissipation Derating	mW/°C	1.5	1.2
P _C	Power Dissipation	mW/Ch	150	120
Coupled				
BV	Isolation Voltage ²	V _{r.m.s.}	5000	5000
T _{STG}	Storage Temperature	°C	-55 to +150	-55 to +150
T _{OPT}	Operating Temperature	°C	-55 to +100	-55 to +100
T _{SOL}	Lead Temperature (Soldering 10 s)	°C	260	260
P _T	Total Power Dissipation	mW/Ch	250	200

Notes:

1. Operation in excess of any one of these parameters may result in permanent damage.
2. AC voltage for 1 minute at T_A = 25 °C, RH = 60 % between input and output.

TYPICAL PERFORMANCE CURVES (T_A = 25 °C)

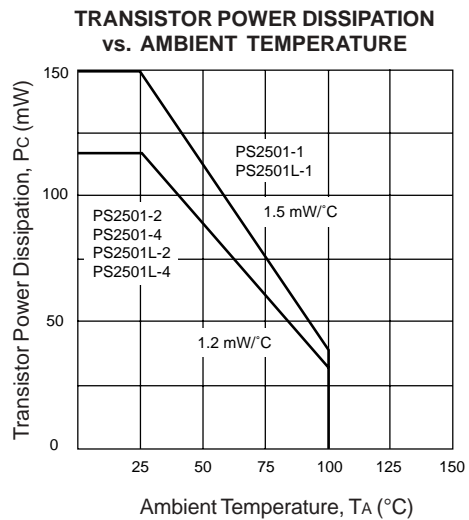
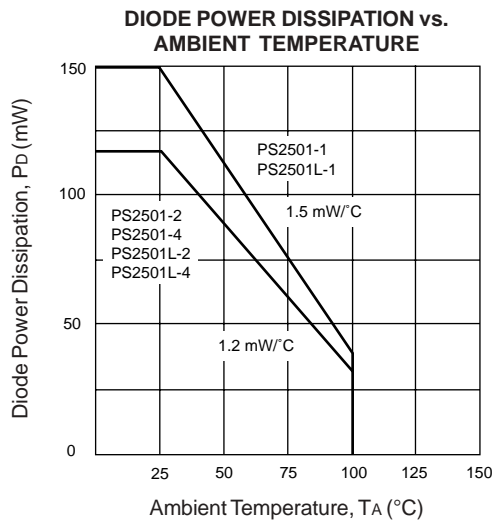

TYPICAL PERFORMANCE CURVES (TA = 25 °C)

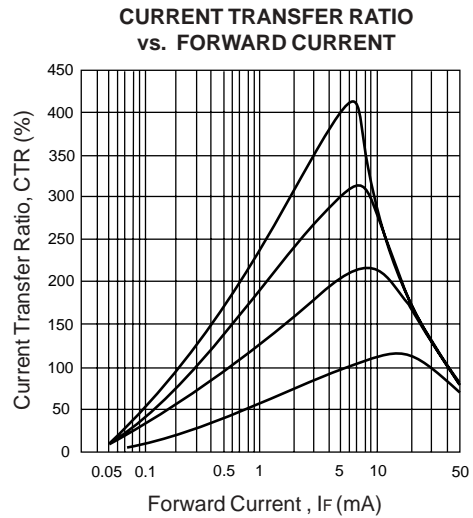
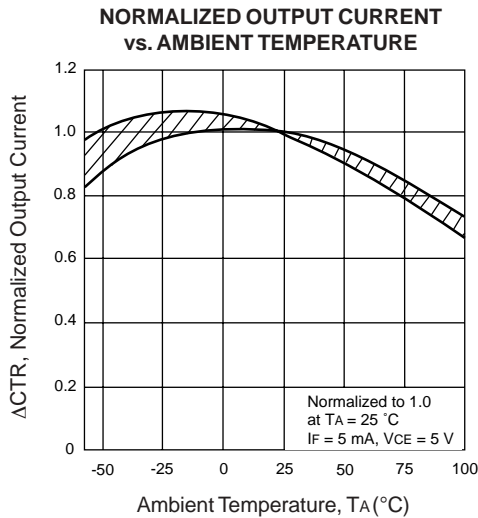
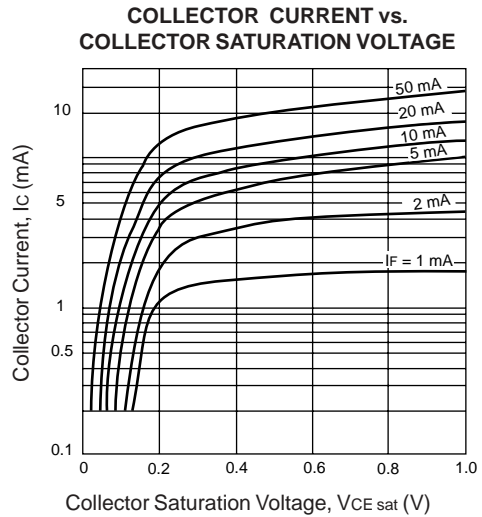
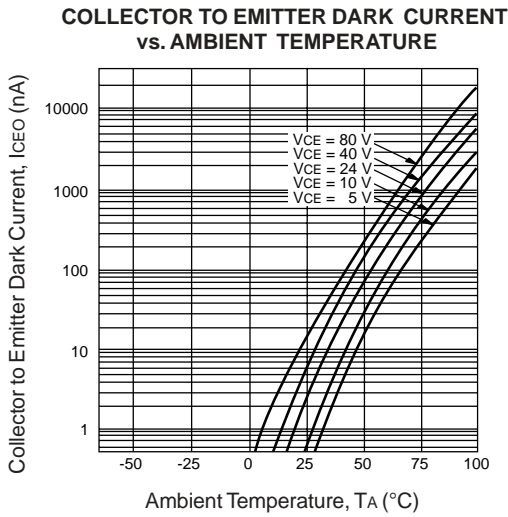
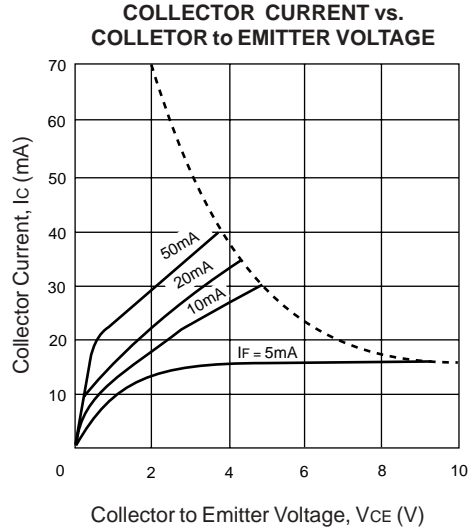
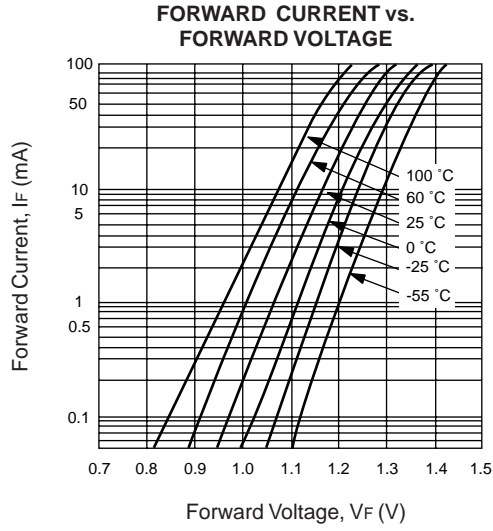

TYPICAL PERFORMANCE CURVES (TA = 25 °C)

SWITCHING TIME vs. LOAD RESISTANCE

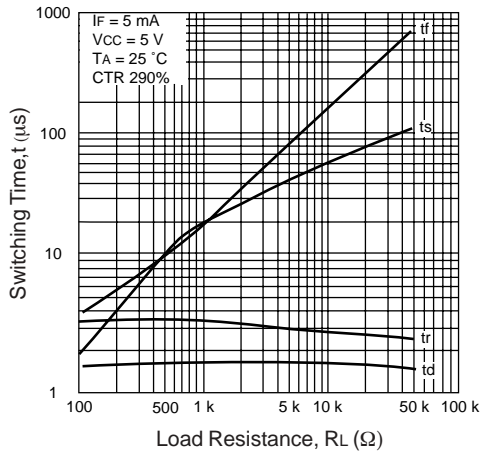

SWITCHING TIME vs. LOAD RESISTANCE

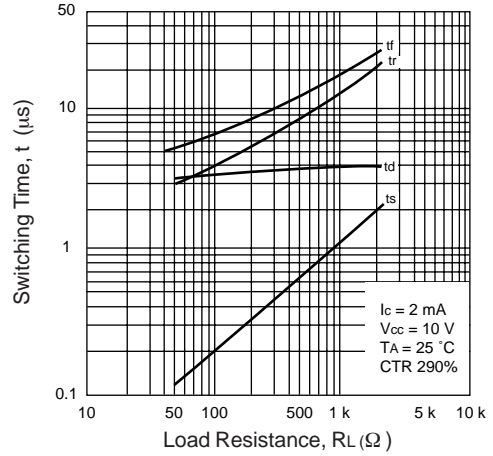

FREQUENCY RESPONSE

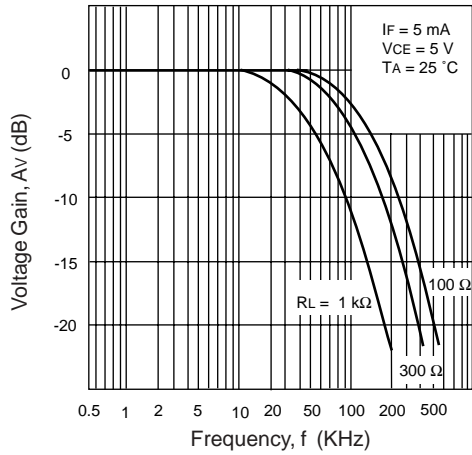

LONG TERM CTR DEGRADATION

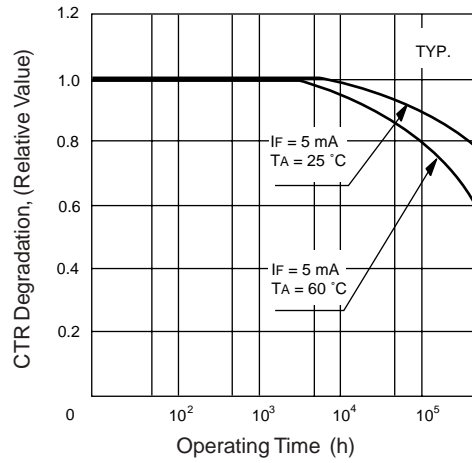

PS2501-1, -2, -4, PS2501L-1, -2, -4

OUTLINE DIMENSIONS (Units in mm) **DIP (Dual In-line Package)**

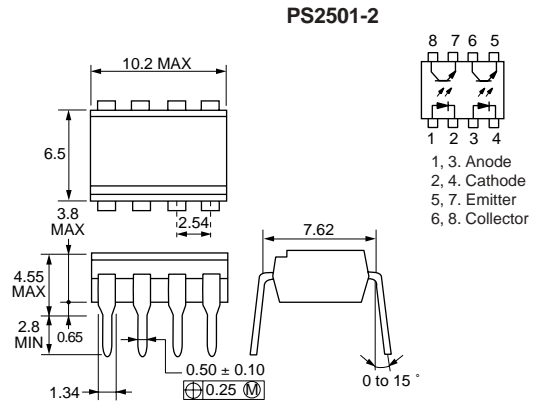
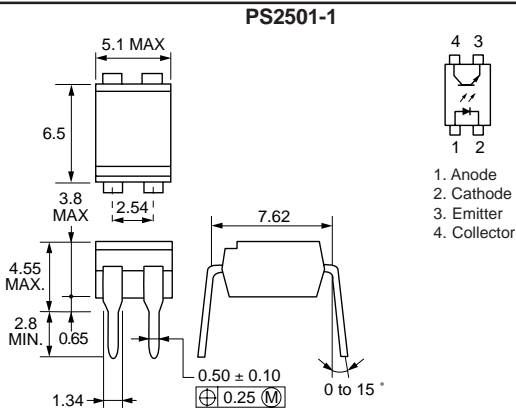

PS2501-4

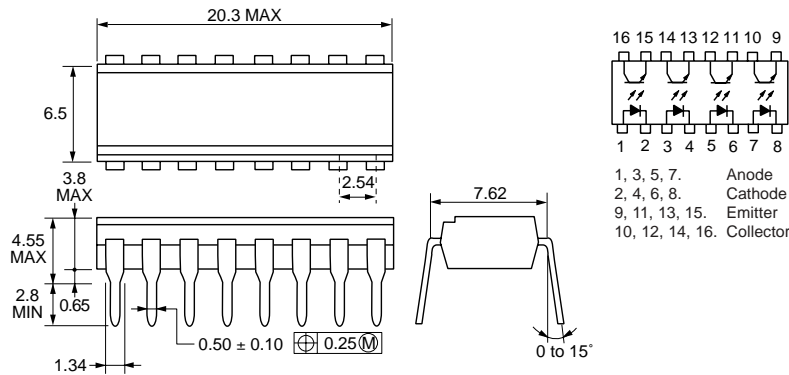

OUTLINE DIMENSIONS (Units in mm) **Lead Bending Type (Gull-wing)**

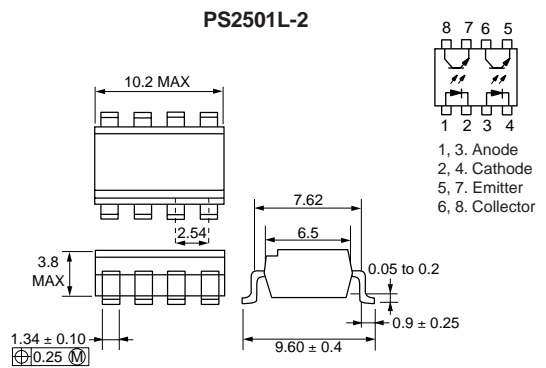
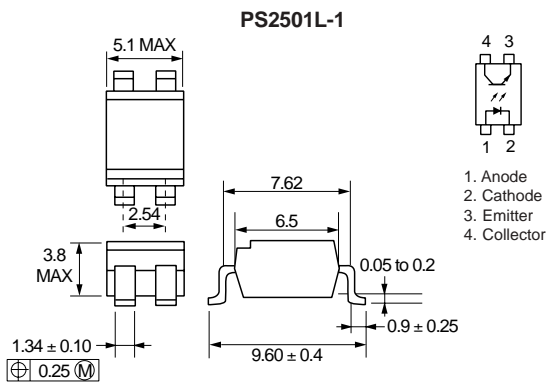

PS2501L-4

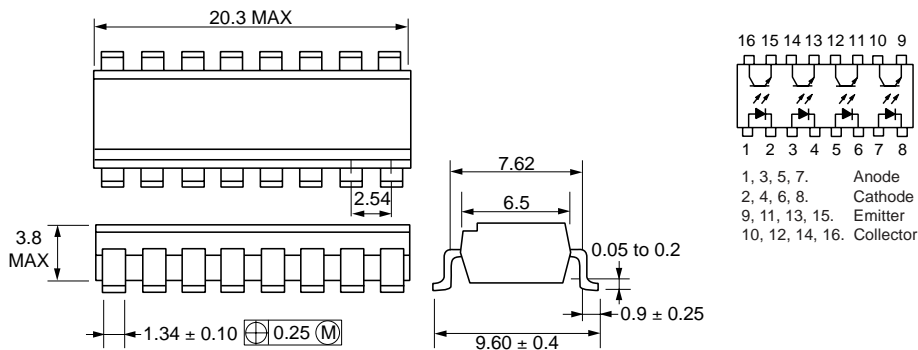

OUTLINE DIMENSIONS (Units in mm)

PS2501-1*

PS2501L-1*

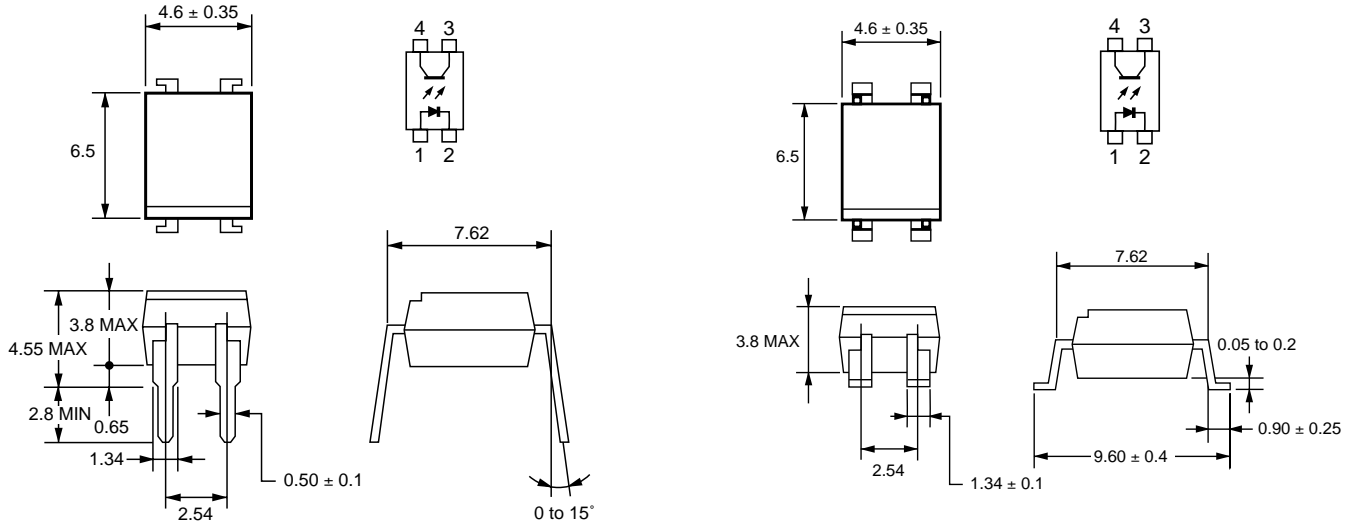

*These packages are manufactured using the new Phoenix manufacturing process, and are interchangeable with the standard PS2501-1 and PS2501L-1.

Life Support Applications

These NEC products are not intended for use in life support devices, appliances, or systems where the malfunction of these products can reasonably be expected to result in personal injury. The customers of CEL using or selling these products for use in such applications do so at their own risk and agree to fully indemnify CEL for all damages resulting from such improper use or sale.

CEL California Eastern Laboratories, Your source for NEC RF, Microwave, Optoelectronic, and Fiber Optic Semiconductor Devices.

4590 Patrick Henry Drive • Santa Clara, CA 95054-1817 • (408) 988-3500 • FAX (408) 988-0279 • www.cel.com

DATA SUBJECT TO CHANGE WITHOUT NOTICE

07/01/2004