

AET-Series TMR Off-Axis Rotational and Linear Sensors

Block Diagram

Half-bridges:

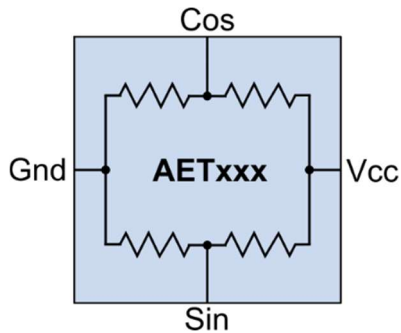

Full Bridges:

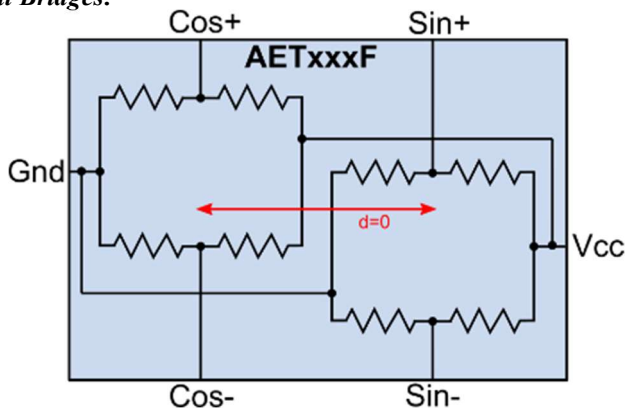

Outputs

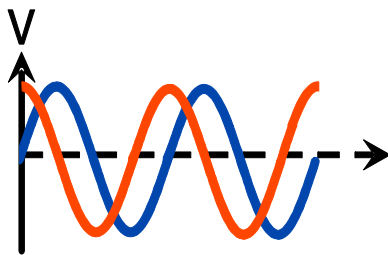

AET-Series operation

Features

- Wide airgap
- Low hysteresis
- Excellent linearity, low distortion
- Large analog peak-to-peak signal
- Operating frequency to 350 kHz
- High 150°C operating temperature

Applications

- Linear and rotational encoders
- Motion, speed, and position sensing
- Closed-loop servo systems
- Motor feedback encoders

Description

NVE's AET-Series sensor elements are versatile, wide-airgap sensors typically used with multipole ring magnets, both radial and face poles, and magnetic linear scale. Standard spacing sensors can detect pole pitches from 0.5 mm to 5 mm. The sensors are Wheatstone bridges comprised of tunneling magnetoresistance (TMR) elements. Both full-bridge and half-bridge versions are available.

The AETxxxF full-bridge sensors offer excellent noise immunity and large differential output signals, and they fully cancel common-mode interference fields.

AETxxx half-bridge sensors combine high performance with a half-bridge outputs interface, ideal for simplicity and miniaturization. They can be influenced by common-mode magnetic fields above 1 millitesla.

Absolute Maximum Ratings

AET-Series TMR Encoder Sensors			
Parameter	Min.	Max.	Units
Supply voltage	-7	7	Volts
Storage temperature	-65	170	°C
ESD (Human Body Model)		2000	Volts
Applied magnetic field		Unlimited	mT

Operating Specifications

Parameter	Symbol	Min.	Typ.	Max.	Units
Operating temperature	$T_{min}; T_{max}$	-50		150	°C
Supply voltage	V_{CC}	0		5.5	V
Resistance		3	5	10	k Ω
Offset voltage	V_O	-20		+20	mV/V
Nonlinearity			1	2	%
Hysteresis			0.5	1	%
Magnetic linear range			± 10		mT
Saturation of TMR sensor elements		± 30			mT
Single resistor sensitivity	$\Delta R/mT$		1%		%/mT
Maximum output					mVpp/V
• AETxxx			200	300	
• AETxxxF (normal mode)			400	600	
• AETxxxF (double pitch mode)			300	450	
Temperature coefficient of device resistance	TCR		-0.08		%/°C
Temperature coefficient of output	TCO	-0.1	0	0.1	%/°C
Operating frequency	f_{MAX}		350		kHz

Magnetic Pitch and Pole Pitch

The AET-Series are linear sensors designed for detecting multipole magnets for off-axis rotational or linear scale applications. The TMR sensor elements are bipolar, meaning they detect both north and south magnetic fields. This gives the sensors large output signals, but it also effectively doubles the “magnetic pitch” from the sensor’s point of view. This concept is shown in Figure 1 below.

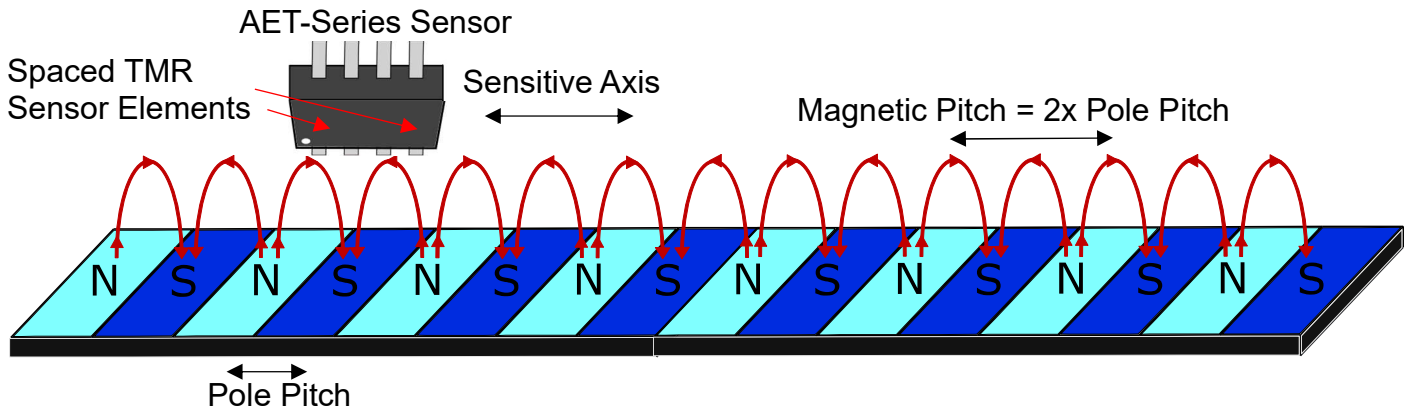

Figure 1: Pole pitch (north to south) vs. magnetic pitch (north to north) on a magnetic linear scale

AET-Series sensors are named based on the north-south “pole pitch” they are optimized to detect. The sensor’s sine and cosine outputs are periodic with the “magnetic pitch.” As an example, to detect a magnetic strip with “pole pitch” (specified by the manufacturer) of 1 mm, choose AET100F-00E. The sensor provides sine and cosine output signals, with a full cycle occurring every 2 mm.

Other common configurations for the AET-Series are illustrated below, where the same comments about “pole pitch” and “magnetic pitch” apply. The sensor output amplitude scales approximately linearly with airgap, reaching the maximum value when the sensor face is at the magnet face. The outputs scale ratiometrically with the supply voltage.

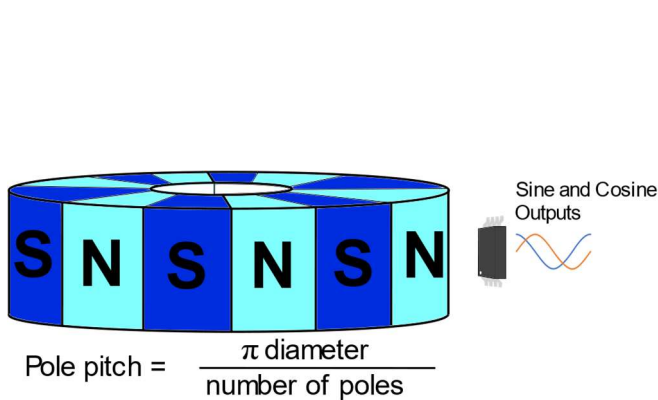

Figure 2: Multipole ring magnet with radial poles.

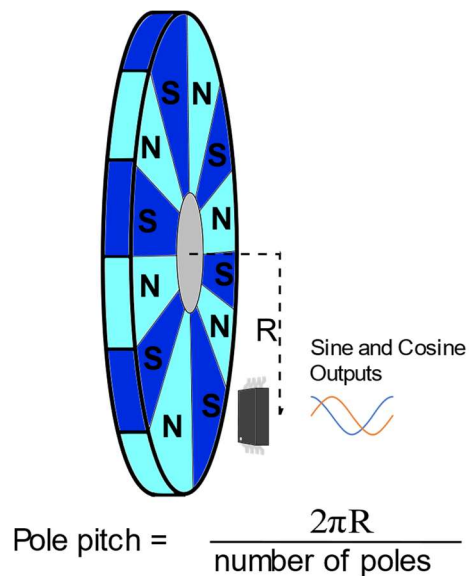

Figure 3: Multipole ring magnet with face poles

AETxxxF Normal Mode and Double Pitch Mode

AETxxxF full bridge sensors can be used in two distinct modes of operation: normal mode and double pitch mode. Double pitch mode optimizes an AETxxxF sensor to measure twice as large a pole pitch as its normal mode. To use double pitch mode, the output signals are rearranged, swapping Sin+ and Cos-. For example, an AET100F-00E sensor is optimized for a 1 mm pole pitch in the normal mode and a 2 mm pole pitch in the double pitch mode connection. Figure 4 illustrates the concept.

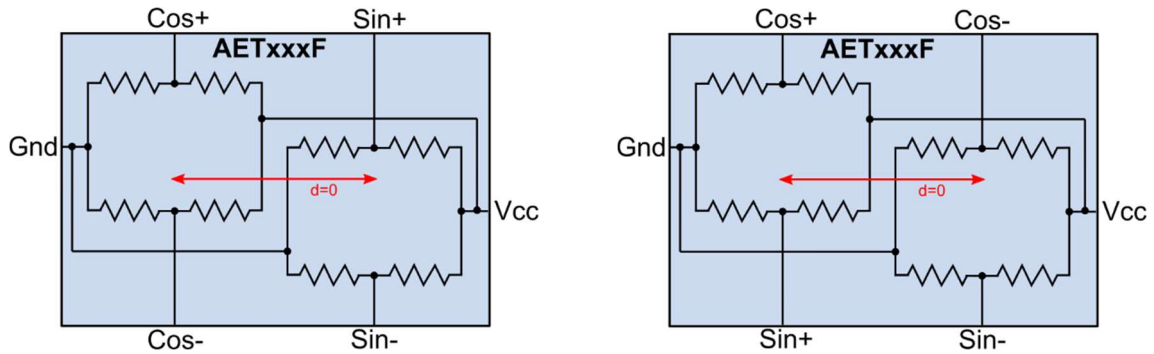

Figure 4: (left) Normal mode and (right) double pitch mode.

Double pitch mode will decrease the maximum output signal by 25% due to the modified effective TMR resistor arrangement, but all other performance characteristics, including common-mode field rejection, are preserved.

Illustrative Application Circuits

Direct Microcontroller Interface

Large output signal and low output impedance allow the AETxxx or AETxxxF to be interfaced directly to a standard microcontroller or ADC. Incremental position information can be obtained with an arctangent function.

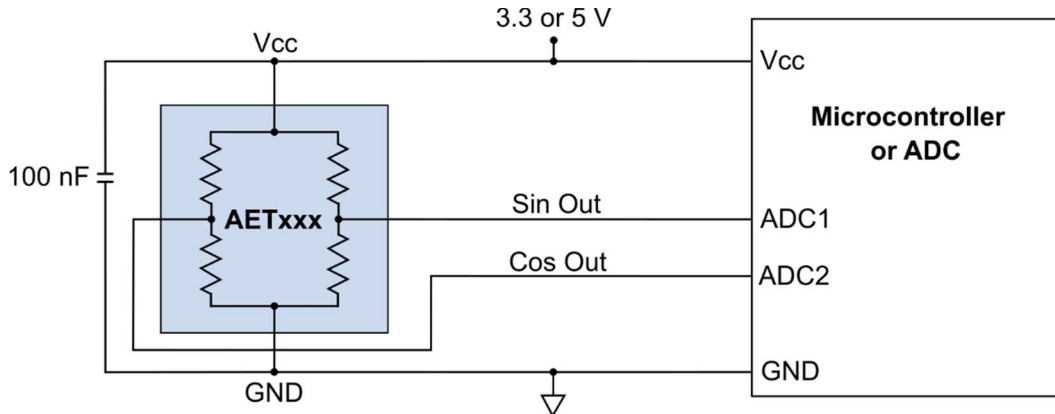

Figure 5. An AETxxx or AETxxxF can be interfaced to an ADC or microcontroller directly, without any external components.

Full-Scale Outputs

While the AET-Series has inherently large output signal, some high-accuracy applications need even larger output signals for better ADC resolution. A low-cost dual op amp circuit like the one in Figure 5 scales the sine and cosine outputs to full scale.

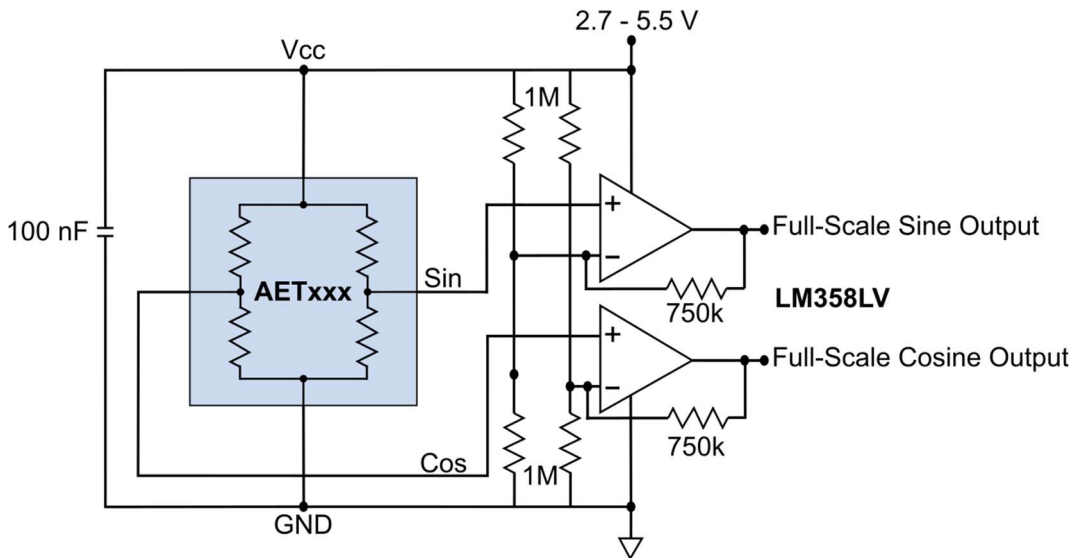
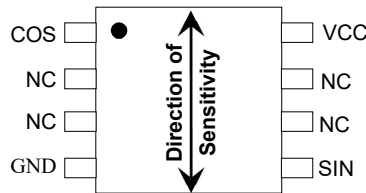

Figure 6. A dual op amp circuit with a gain of 2.5 scales the 300 mVpp/V AETxxx outputs to near full-scale.

AETxxx Pinout (top view)

SOIC8
(-02E suffix)



SOIC8	Symbol	Description
8	VCC	Bridge power supply
4	GND	Bridge ground
1	COS	Cosine half-bridge output
5	SIN	Sine half-bridge output
2,3,6,7	NC	Leave floating

AETxxxF Pinout (top view)

MSOP8 / SOIC8
(-00E / -02E suffix)

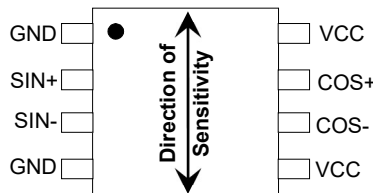

Pin	Symbol	Description
5	VCC	Bridge power supply*
8	VCC	Bridge power supply*
1	GND	Bridge ground*
4	GND	Bridge ground*
2	SIN+**	Sine bridge differential output
3	SIN-	
6	COS+	Cosine bridge differential output
7	COS-**	

*Pin 5 and pin 8 should both have an external connection to VCC, and Pin 1 and Pin 4 should both have an external connection to GND.

**Swap COS- and SIN+ connections for AETxxxF double pitch mode.

Part Numbering

The following example shows the AET-Series part-numbering system:

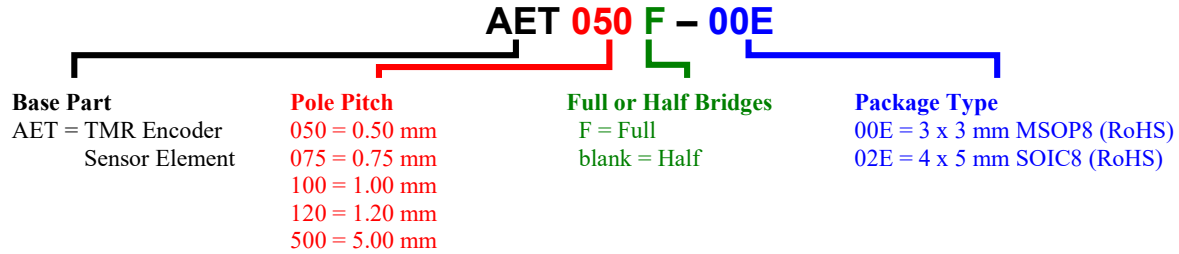

Available Parts

AET-Series TMR Sensors					
Part No.	Half or Full Bridges	Pole Pitch (normal mode)	Pole Pitch (double pitch mode)	Package	Package Marking Code
AET500-02E	Half	5 mm	N/A	SOIC8	AET500
AET050F-00E	Full	0.5 mm	1 mm	MSOP8	FTDe
AET075F-00E	Full	0.75 mm	1.5 mm	MSOP8	FTCe
AET100F-00E	Full	1 mm	2 mm	MSOP8	FTBe
AET120F-00E	Full	1.2 mm	2.4 mm	MSOP8	FTEe

Package Drawings

MSOP8 (-00E suffix)

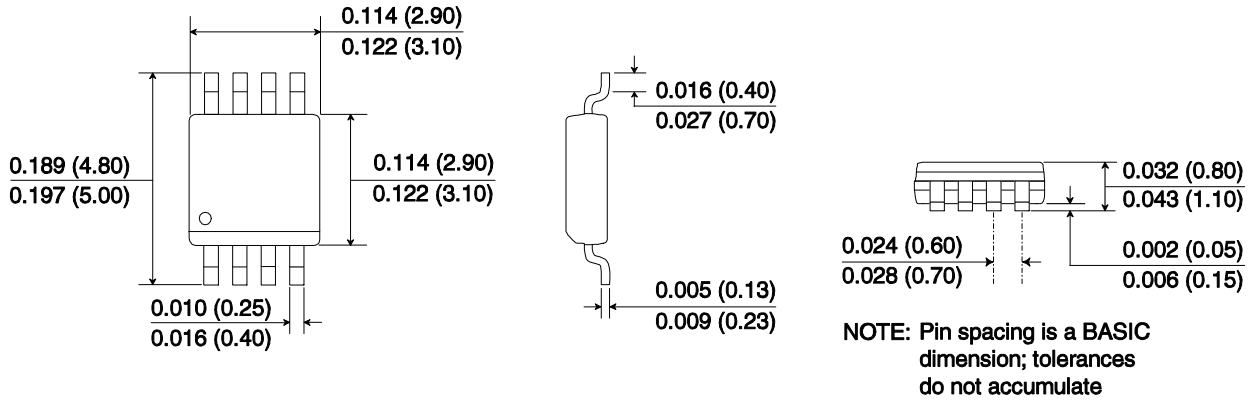

RoHS
COMPLIANT

SOIC8 (-02 suffix)

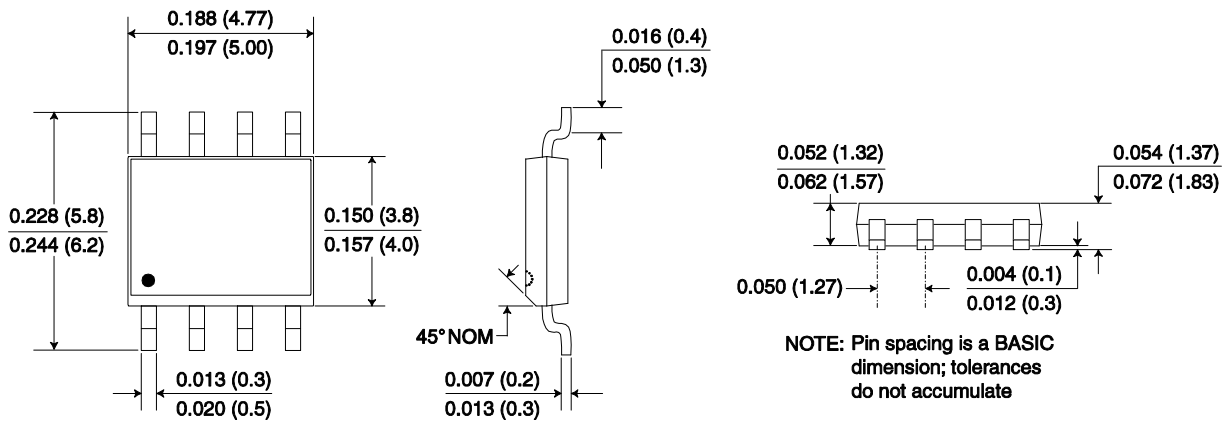

RoHS
COMPLIANT

All soldering profiles per JEDEC J-STD-020C, MSL 1.

Revision History

SB-00-118-A
September 2020

Change

- Initial datasheet release.

Datasheet Limitations

The information and data provided in datasheets shall define the specification of the product as agreed between NVE and its customer, unless NVE and customer have explicitly agreed otherwise in writing. All specifications are based on NVE test protocols. In no event however, shall an agreement be valid in which the NVE product is deemed to offer functions and qualities beyond those described in the datasheet.

Limited Warranty and Liability

Information in this document is believed to be accurate and reliable. However, NVE does not give any representations or warranties, expressed or implied, as to the accuracy or completeness of such information and shall have no liability for the consequences of use of such information.

In no event shall NVE be liable for any indirect, incidental, punitive, special or consequential damages (including, without limitation, lost profits, lost savings, business interruption, costs related to the removal or replacement of any products or rework charges) whether or not such damages are based on tort (including negligence), warranty, breach of contract or any other legal theory.

Right to Make Changes

NVE reserves the right to make changes to information published in this document including, without limitation, specifications and product descriptions at any time and without notice. This document supersedes and replaces all information supplied prior to its publication.

Use in Life-Critical or Safety-Critical Applications

Unless NVE and a customer explicitly agree otherwise in writing, NVE products are not designed, authorized or warranted to be suitable for use in life support, life-critical or safety-critical devices or equipment. NVE accepts no liability for inclusion or use of NVE products in such applications and such inclusion or use is at the customer's own risk. Should the customer use NVE products for such application whether authorized by NVE or not, the customer shall indemnify and hold NVE harmless against all claims and damages.

Applications

Applications described in this datasheet are illustrative only. NVE makes no representation or warranty that such applications will be suitable for the specified use without further testing or modification.

Customers are responsible for the design and operation of their applications and products using NVE products, and NVE accepts no liability for any assistance with applications or customer product design. It is customer's sole responsibility to determine whether the NVE product is suitable and fit for the customer's applications and products planned, as well as for the planned application and use of customer's third party customers. Customers should provide appropriate design and operating safeguards to minimize the risks associated with their applications and products.

NVE does not accept any liability related to any default, damage, costs or problem which is based on any weakness or default in the customer's applications or products, or the application or use by customer's third party customers. The customer is responsible for all necessary testing for the customer's applications and products using NVE products in order to avoid a default of the applications and the products or of the application or use by customer's third party customers. NVE accepts no liability in this respect.

Limiting Values

Stress above one or more limiting values (as defined in the Absolute Maximum Ratings System of IEC 60134) will cause permanent damage to the device. Limiting values are stress ratings only and operation of the device at these or any other conditions above those given in the recommended operating conditions of the datasheet is not warranted. Constant or repeated exposure to limiting values will permanently and irreversibly affect the quality and reliability of the device.

Terms and Conditions of Sale

In case an individual agreement is concluded only the terms and conditions of the respective agreement shall apply. NVE hereby expressly objects to applying the customer's general terms and conditions with regard to the purchase of NVE products by customer.

No Offer to Sell or License

Nothing in this document may be interpreted or construed as an offer to sell products that is open for acceptance or the grant, conveyance or implication of any license under any copyrights, patents or other industrial or intellectual property rights.

Export Control

This document as well as the items described herein may be subject to export control regulations. Export might require a prior authorization from national authorities.

Automotive Qualified Products

Unless the datasheet expressly states that a specific NVE product is automotive qualified, the product is not suitable for automotive use. It is neither qualified nor tested in accordance with automotive testing or application requirements. NVE accepts no liability for inclusion or use of non-automotive qualified products in automotive equipment or applications.

In the event that customer uses the product for design-in and use in automotive applications to automotive specifications and standards, customer (a) shall use the product without NVE's warranty of the product for such automotive applications, use and specifications, and (b) whenever customer uses the product for automotive applications beyond NVE's specifications such use shall be solely at customer's own risk, and (c) customer fully indemnifies NVE for any liability, damages or failed product claims resulting from customer design and use of the product for automotive applications beyond NVE's standard warranty and NVE's product specifications.

An ISO 9001 Certified Company

NVE Corporation
11409 Valley View Road
Eden Prairie, MN 55344-3617 USA
Telephone: (952) 829-9217
Fax: (952) 829-9189
www.nve.com
e-mail: sensor-info@nve.com

©NVE Corporation
All rights are reserved. Reproduction in whole or in part is prohibited without the prior written consent of the copyright owner.

SB-00-118

September 2020