

SM124-10E GMR Smart Magnetometer

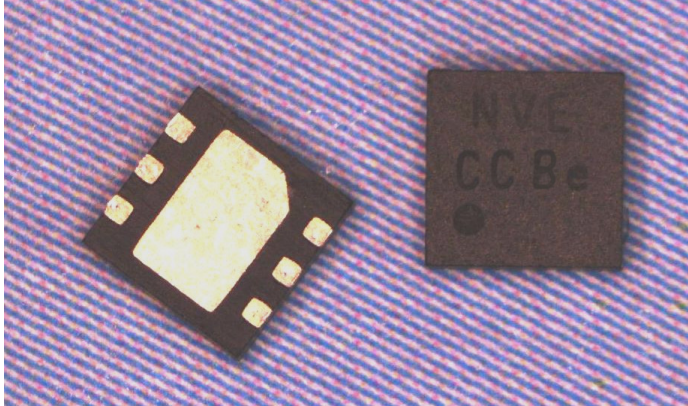

Features

- Sensitive (0 to 10 Oe / 0 to 1 mT linear range)
- Can detect magnets more than 50 mm away
- Slick, single-byte communication interface
- Analog field measurement plus on/off digital output
- Internal temperature compensation
- Factory calibrated
- Programmable offset and gain correction
- In-plane sensitivity—more usable than Hall effect sensors
- Optional magnet temperature compensation
- 2.2 to 3.6V supply
- 3.3 or 5V compatible I²C interface
- Ultraminiature 2.5 x 2.5 x 0.8 mm TDFN6 package

Key Specifications

- 8 bit / 1% output resolution
- -40°C to +125°C operating range
- 5% FS accuracy for 0 to 85°C
- 10 kSps sample rate for fast response
- 6 mA typical supply current

Simplified Block Diagram

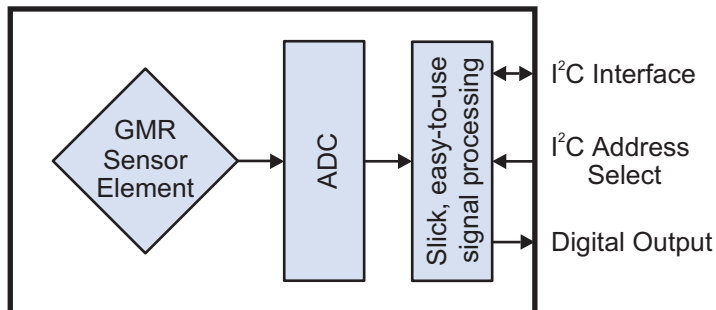

Applications

- Proximity sensing
- Current sensing
- Security and intrusion detection
- Automotive applications
- Cylinder position sensing

Description

SM124 Smart Magnetometers provide precise magnetic field measurements. The sensors combine Giant Magnetoresistance (GMR) sensor elements with easy-to-use digital signal processing.

Unlike awkward, old-fashioned Hall-effect sensors, GMR is sensitive in-plane for optimal current sensing and easy mechanical interfaces. GMR also provides more sensitivity, higher precision, higher speed, and lower noise than Hall.

A digital output provides precise, programmable thresholds. An I²C interface provides magnetic field data, as well as a calibration interface. The device is factory calibrated for high accuracy. Calibration coefficients are stored in internal nonvolatile memory.

All commands, data, and coefficients are a single byte, and a slick, elegant data structure lets you get up and running with a minimum of firmware.

Transfer Functions

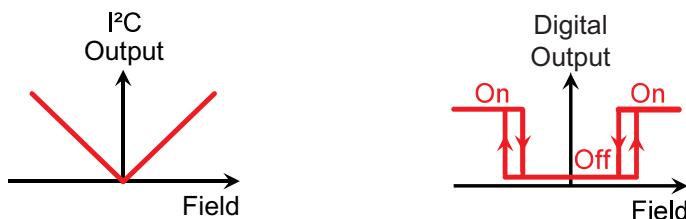

Absolute Maximum Ratings

Parameter	Min.	Max.	Units
Supply voltage	-0.3	4.2	Volts
SCL and SDA input voltages	-0.5	V _{cc} + 2.5 up to 5.8	Volts
Storage temperature	-55	150	°C
ESD (Human Body Model)		2000	Volts
Applied magnetic field		Unlimited	Oe

Operating Specifications

T _{min} to T _{max} ; 2.2 < V _{DD} < 3.6 V unless otherwise stated.						
General	Symbol	Min.	Typ.	Max.	Units	Test Condition
Operating temperature	T _{min} ; T _{max}	-40		125	°C	
Supply voltage	V _{DD}	2.2		3.6	V	
Supply current	I _{DD}		6	7	mA	Max. at V _{DD} = 3.6V
Power-on Reset supply voltage	V _{POR}		1.4		V	
Brown-out power supply voltage	V _{BOR}	0.75	1	1.36	V	
Digital out high voltage	V _{OH}	V _{DD} - 0.7			V	I _{OH} = -5 mA
Digital out low voltage	V _{OL}	0.5			V	I _{OL} = 15 mA
Magnetics						
Linear range		0		10	Oe	
Saturation			15			
Resolution	δH		0.1			
Accuracy (% of linear range)				±5	% FS	0 to 85°C, Unipolar
				±10		-40 to 125°C, Unipolar
Precision and Speed						
Resolution			±1		%	
Digital precision			7		bits	
Sample rate			10		kSps	
Output response time			85		µs	
Start-up time	T _{STA}		1		ms	
Internal Temperature Sensor						
Temperature accuracy (factory calibrated)				±2.5	°C	25 to 85°C
				±5	°C	-40 to 125°C
I ² C Interface						
Data transfer rate	DR			400	kBaud	
Bus voltage	V _{BUS}	2.2		5.5	V	
Output response and transmission times				20	µs	400 kBaud
Low level input threshold voltage	V _{IL}	0.8			V	
High level input threshold voltage	V _{IH}			2.2	V	
Low level output current	I _{OL}	3		mA		V _{OL} = 0.4V
I/O capacitance	C _{I/O}			10	pF	
Nonvolatile Memory						
Write time				15	msec	
Endurance			10,000		Cycles	
Package Thermal Characteristics						
Junction-to-ambient thermal resistance	θ _{JA}		320		°C/W	
Package power dissipation			500		mW	

SM124 Overview

Direction of Magnetic Sensitivity

As the field varies in intensity, the digital output will turn on and off. Unlike Hall effect or other sensors, the direction of sensitivity is in the plane of the package. The diagrams below show two permanent magnet orientations that will activate the sensor in the direction of sensitivity:

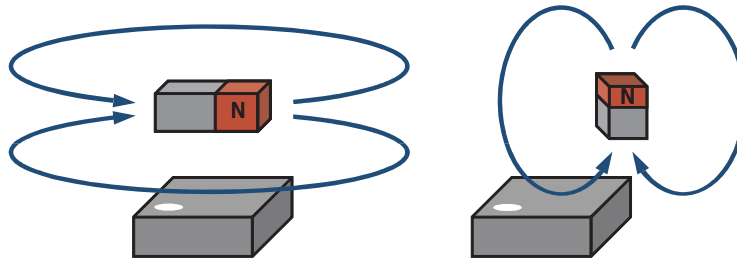

Figure 1. Direction of magnetic sensitivity.

These sensors are “omnipolar,” meaning the outputs turn ON when a magnetic field of either magnetic polarity is applied.

Typical Operation

Position Sensing

A typical proximity sensor using an SM124-10E sensor and magnet is shown below. With a 4 Oe operate point, the sensor actuates with a rare-earth magnet at more than 50 mm (two inches) from the sensor:

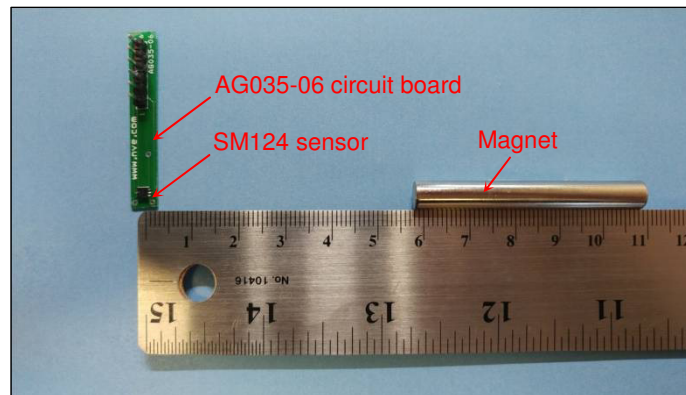

Figure 2. The SM124-10E sensor can be activated by a magnet more than 50 mm away. Maximum sensitivity is in plane with the sensor, with the magnet axis in the pin 2/pin 5 sensor axis. The part is sensitive to either north or south fields.

Thresholds even lower than 4 Oe can be programmed, although care must be taken to account for the earth’s magnetic field, which is typically in the 0.5 Oe range.

Typical magnetic operate distances for the SM124 is illustrated in the following graph with an inexpensive ceramic disk magnet:

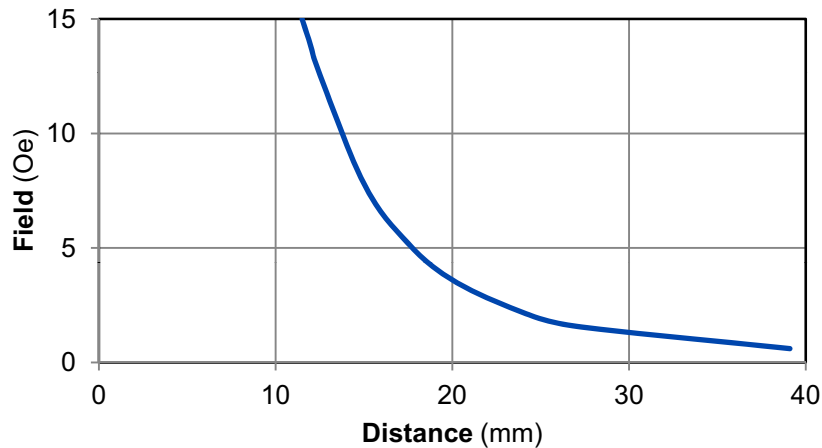

Figure 3. Field vs. distance from the center of the sensor
(NVE part number 12216; ferrite magnet; d=6 mm; t=4 mm; C1/Y10T; $M_s=B_r=2175$ G).

Larger and stronger magnets allow farther operate and release distances. For more calculations, use our axial disc magnetic field versus distance Web application at:

www.nve.com/spec/calculators.php#tabs-Axial-Disc-Magnet-Field.

Noncontact Current Sensing

SM124 sensors can measure the current through a circuit board trace by detecting the magnetic field generated by the current through the trace. The sensor is ideal for these applications because of the low fields generated. The digital output can be used for current threshold detection or overcurrent protection.

Typical current sensing configurations are shown below:



Figure 4a. 0.05" (1.3 mm) trace on top of PCB
(2.8 Oe/amp; 0 to 3.5 A linear)

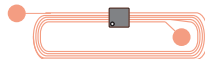

Figure 4b. Five-turn, 0.0055" (0.14 mm) trace on top of PCB
(14 Oe/amp; 0 to 700 mA linear range).

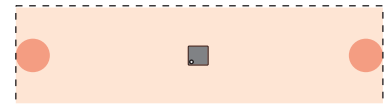

Figure 4c. 0.5" (13 mm) trace on bottom of 0.15" (3.8 mm) thick PCB
(0.4 Oe/amp; 0 to 30 A linear range).

For the geometry shown below and narrow traces, the magnetic field generate can be approximated by Ampere’s law:

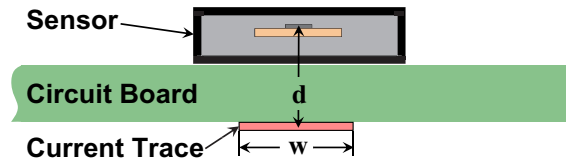

Figure 4. The geometry of current-sensing over a circuit board trace.

$$H = \frac{2I}{d} \quad [\text{“H” in oersteds, “I” in amps, and “d” in millimeters}]$$

For traces on the top side of the board, “d” is simply the distance of the sensor element from the bottom of the package, which is 0.5 millimeters.

Traces on the top side of the board are typically used for currents of 2.5 amps or less. Large traces on the bottom side of the PCB can be used for currents of up to 30 amps.

More precise calculations can be made by breaking the trace into a finite element array of thin traces, and calculating the field from each array element. We have a free, Web-based application with a finite-element model to estimate magnetic fields and sensor outputs in this application:

www.nve.com/spec/calculators.php#tabs-Current-Sensing

Operation

A detailed block diagram is shown below:

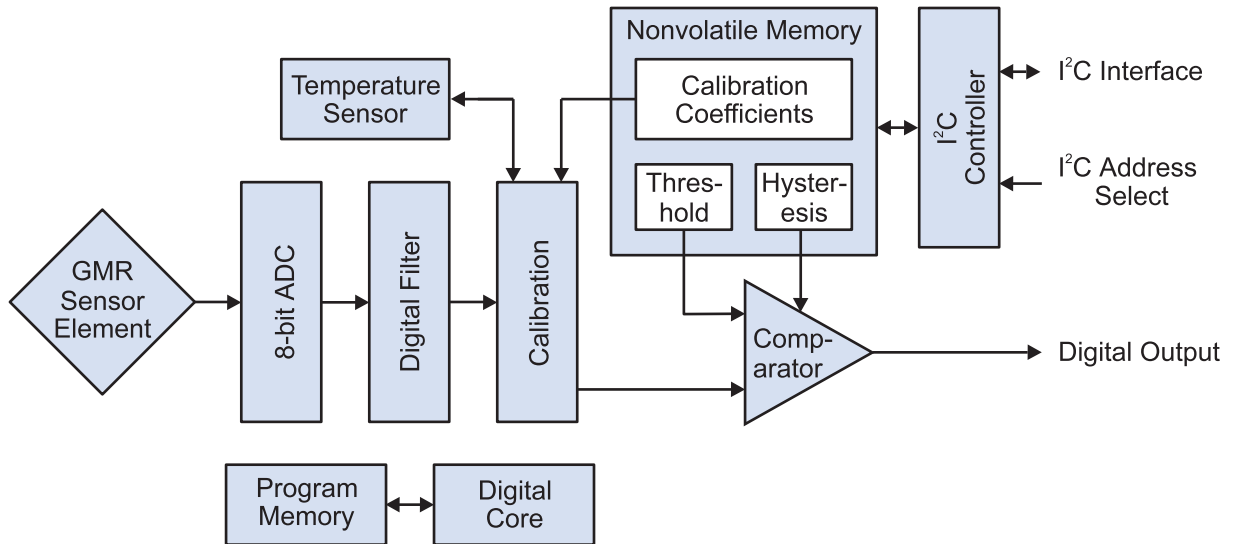

Figure 5. Detailed block diagram.

Sensor Element

SM124 sensors use unique GMR sensor elements that are inherently high sensitivity, high speed, and low noise.

ADC

The sensor output is digitized with an eight-bit ADC.

Digital Filter

A first-order Infinite Impulse Response (IIR) digital filter with a programmable cutoff frequency can be used for ultralow noise if high-frequency operation is required. The factory default is the filter turned off.

Single-Byte Addresses, Data, and Parameters

All data and parameters are input and output as single bytes (eight bits). This provides at least 1% precision while eliminating the need to concatenate upper and lower bytes.

No Communications Overhead

Data are always valid, so there is no need to wait for data during an I²C read, and there are no set-up commands or error handling required.

Sensitivity and Offset Calibration

The sensor element is factory calibrated for sensitivity, offset, linearity, and temperature compensation. The user can also calibrate the output for a particular system.

A sensor calibration curve is illustrated below:

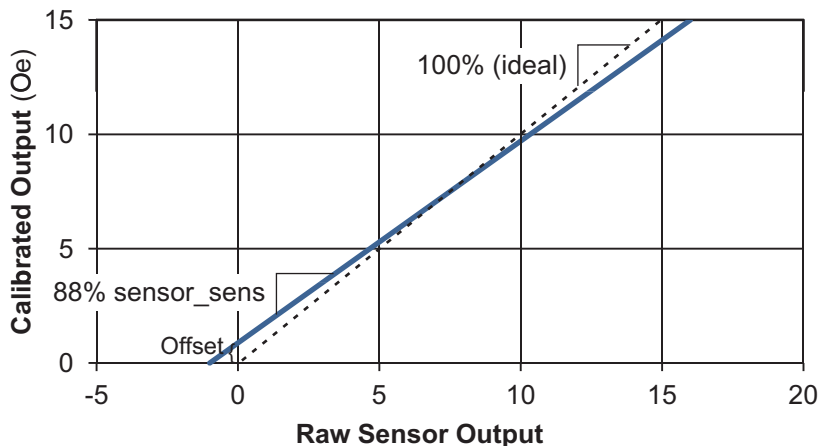

Figure 6. Illustrative sensor calibration curve.

There are two sensor calibration parameters, sensitivity and offset. Sensitivity is expressed as a percentage of nominal; offset is expressed as bits out of seven bits full scale. Calibration parameters are stored in nonvolatile memory, and can be read or written via I²C.

Mathematically, the corrected sensor output is calculated as follows:

$$\text{sensor} = ((\text{temperature}) * \text{tempco} / 100000 + 1) * (\text{sensor_raw}) / \text{sensor_sens} - \text{sensor_offset}$$

where “sensor” is the corrected sensor output, “temperature” is the measured temperature in °C, and the other operands are parameters provided from factory calibration. “tempco” is expressed in %/1000°C and as a positive number for convenience although GMR actually has a negative temperature coefficient, meaning it is less sensitive at higher temperatures.

Magnet Temperature Compensation

There are optional magnet temperature profiles that also compensate for the loss of magnetic field strength as temperature increases. Two profiles are available: one for low-cost ferrite magnets and another for high field rare-earth magnets. Writing a number to address 0x2B sets the compensation profile: “0” is the default profile and provides no magnet temperature compensation; “1” compensates for ceramic or ferrite magnets, and “2” compensates for NdFeB or rare-earth magnets.

Temperature Sensor

An internal temperature sensor is used to compensate the sensor element, and the temperature sensor itself is factory calibrated for slope and offset. Like magnetic field, temperature can be read via I²C and can also be user calibrated.

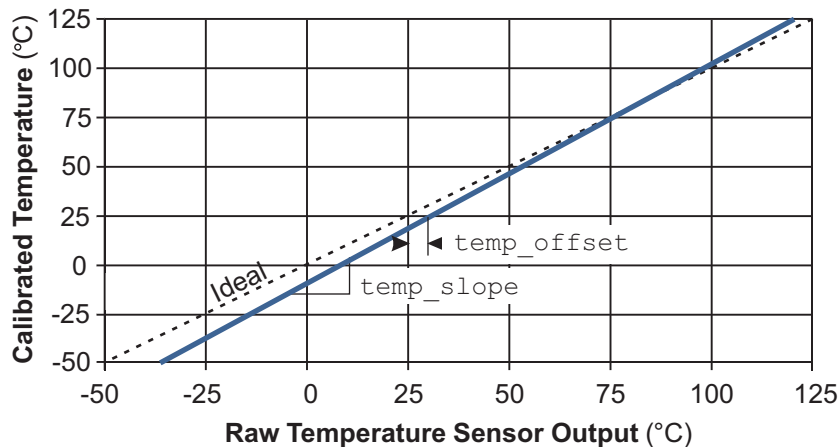

Figure 7. Temperature sensor calibration.

Mathematically, temperature is corrected as follows:

$$\text{temperature} = (\text{temperature_raw}) * 100 / \text{temp_slope} + \text{temp_offset}$$

where “temp_offset” is the temperature error at 0°C (positive indicating the sensor reads low); and temp_slope is the temperature sensor sensitivity expressed as a percent of ideal; greater than 100% indicates the sensor reads high.

Comparator and Digital Output

A digital comparator drives the Digital Output (“DOUT”) pin, which by default goes HIGH when the sensor field exceeds the threshold, then LOW when the field drops below the threshold minus hysteresis as illustrated below:

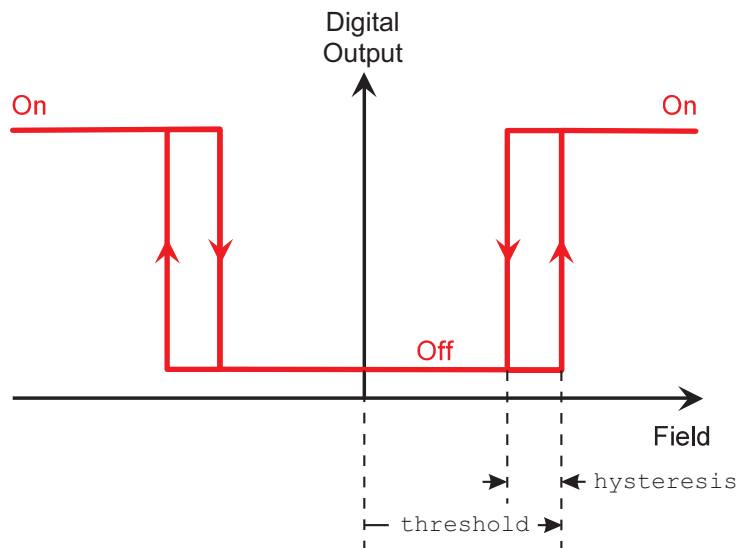

Figure 8. Digital Output parameters.

Unlike some other parts, the digital output is continuously updated at high speed and runs independently of the I²C interface. The SM124 can therefore be used with factory defaults or customer programmed Digital Output parameters without an I²C connection.

Threshold and hysteresis parameters are expressed as percentages of the sensor’s linear range and are set and stored in nonvolatile memory. Threshold parameters can be set once for the life of the device if desired.

The “DOUT_invert” parameter can be set to invert DOUT. DOUT has high output drive capability, especially current-sinking. Inverting DOUT and connecting an LED, relay, or other load between V_{DD} and DOUT takes advantage of the Digital Output’s strong current-sinking capability.

Latching Mode

If *Hysteresis* is greater than *Threshold*, DOUT will latch ON when the field exceeds the threshold. A *Hysteresis* value of 255 (dec) can be used to ensure the latching mode. The output can be reset by setting it to zero via I²C or by cycling the sensor power. This mode can be used to implement a “virtual circuit breaker” for overcurrent protection.

Graceful Saturation

Unlike other magnetic sensor technologies, GMR sensing elements gradually saturate at high fields, rather than suddenly becoming unresponsive. This allows over-field sensing if high accuracy is not required, such as detecting tamper fields or high fault currents. The linear range is up to 10 Oe, which corresponds to an output value of 100, but sensor typically does not saturate until 15 Oe and the digital resolution extends to 255, which allows measurements all the way to saturation. The typical magnetic response is illustrated below:

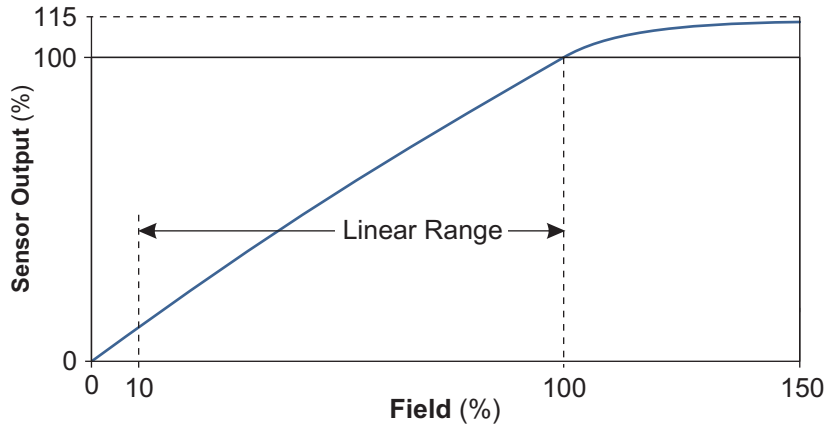

Figure 9. Graceful saturation of sensor element.

Temperature Compensation

SM124 sensors compensate for an inherent slight decrease in GMR sensitivity with temperature. Each sensor is factory calibrated and do not normally need to be recalibrated. If necessary, however, the temperature coefficient can be rewritten, or the user's sensor system can be calibrated based on a coefficient incorporating the change in magnet strength with temperature.

The sensor also has built-in options to compensate for magnet strength degradation with temperature. The magnet compensation uses established residual induction temperature coefficients. Two corrections are available: one for ferrite ceramic magnets, and the other for neodymium rare-earth magnets.

Restoring Factory Calibration

Writing a "1" to sensor memory location 0x7 restores factory calibration settings.

I²C Interface

The I²C interface is an industry standard full-duplex 400 kHz connection with the sensor as the slave to an external master such as a microcontroller. I²C Data (SDA) and Clock (SCL) are 3.3- and five-volt compliant.

Consistent with industry practice, SDA is open-drain, and a pull-up resistor to V_{DD} is normally needed.

A schematic of a typical 3.3- or five-volt microcontroller interface is show in the "Typical Circuit" section of this datasheet.

Factory Programming

Factory programming of any parameters is available Contact us for specifics.

Applications Information

Supply Decoupling

V_{DD} should be bypassed with a 0.1 μ F capacitor placed as close as possible to the V_{DD} and GND pins.

I²C Address

In accordance with industry standards, SM124 sensors have eight-bit I²C addresses (seven bits plus a R/W bit). The I²C standard reserves addresses 0 to 7, so allowable I²C addresses are 8 to 127. Note that some I²C Master devices (such as Arduinos) send seven-bit addresses. In this case, the SM124 address should be divided by two, so for example a default I²C address of 36 rather than 72 would be used.

Changing the I²C Address in Nonvolatile Memory

The I²C address is stored in nonvolatile memory, and can be changed like any other parameter. If there are multiple SM124s on the same I²C bus, however, there will be a collision before addresses can be changes. Therefore changing the address in this way may require a single-sensor programming setup.

Changing the I²C Address with an External Jumper

The I2CADDR pin is read on power-up. If the pin is not connected or tied to V_{DD} , the I²C address will default to 72 dec (88 hex). Grounding the pin changes the I²C address to 16 dec (10 hex).

The nonlinear resistor progression maximizes the separation between voltages to allow for tolerances of the internal pull-up and external resistor. One-percent resistor tolerances are recommended.

Elegant Architecture

The SM124 uses a unique “Von Neumann” architecture where all data and parameters are written and read from memory. This eliminates the need for explicit commands. In addition, all data and coefficients are just one byte, which dramatically simplifies firmware, streamlines system development, and allows high-speed communication over a simple two-wire I²C interface.

Reading and Writing the Sensor Memory

Data is read by first writing an address byte to the sensor (with the I²C Read/Write bit set to “Write”). Subsequent I²C read commands will return the data or parameter in the active address. The address does not need to be re-sent before every read, so data can be read repetitively with only a single-byte read.

The default memory address is 0, which points to the calibrated sensor output, so “out of the box” the sensor output can simply be retrieved with I²C read commands.

Reads from unsupported addresses will return 0xFF; writing to unsupported addresses has no effect.

Memory Allocation

Addresses 0 to F hex are read-only data stored in RAM; addresses 20 to 2F hex are read/write calibration parameters stored in nonvolatile memory; and addresses 80 to 8F hex are constants stored in Read Only Memory:

	Symbol	Default	Read/Write	Range	Address	Description
RAM (0x hex)						
Sensor (calibrated)	Sensor		R	0 – 255	0x00	100 = 10 Oe / 1 mT
Sensor (uncalibrated)	Sensor_Raw		R	-128 – 127	0x01	Raw bridge output, unsigned. Wraps around if overflow.
Temperature	Temperature		R	-128 – 127	0x02	°C
Digital output	DOUT		R/W	0 – 1	0x03	Writing resets the output if latched
V _{I2CADDR}	I2CADDR		R	0 – 255	0x04	I2CADDR pin voltage (read on power-up; 0 = GND; 255 = V _{DD})
Factory setting restore			R	0 – 1	0x05	Writing a “1” restores factory calibration parameters
Nonvolatile Memory (2x hex)						
Sensor digital threshold	threshold	100	R/W	1 – 255	0x20	100 = 10 Oe / 1 mT
Magnetic threshold differential	hysteresis	10	R/W	0 – 127	0x21	100 = 10 Oe / 1 mT; 255 invokes latching
Digital output invert	DOUT_invert	0	R/W	0 – 1	0x22	HIGH to invert DOUT
Sensor offset	sensor_offset	0	R/W	-128 – 127	0x23	
Sensor sensitivity	sensor_sens	100	R/W	0 – 256	0x24	% of spec.
Temperature coef. of sensitivity	tempco	100	R/W	0 – 256	0x25	% of spec.
Temperature sensor offset	temp_offset	0	R/W	-128 – 127	0x26	°C
Temperature slope	temp_slope	100	R/W	0 – 256	0x27	Temp. cal. curve (%)
Digital filter constant	m	1	R/W	1 – 127	0x29	$f_{CUTOFF} = f_{SAMPLE}/(2\pi m)$; $f_{SAMPLE} = 10 \text{ kSps}$ $m = 1$ disables filter
I ² C pull-ups enabled		1	R/W	0 – 1	0x2A	1 = enable pull-ups (no pull-ups on Master); 0 = disable pull-ups (pull-ups on Master)
Magnet temperature compensation profile	magnet_comp	0	R/W	0 – 2	0x2B	0 = no compensation 1 = ceramic magnet 2 = NdFeB magnet
Read-Only Memory (8x hex)						
Lot code			R		80 – 85	Date code in ASCII; right-most character in address 80; left-most in address 85; format YYWWXX, where YY = year; WW = work week; XX = internal code.

Table 2. SM124 memory addresses.

Power-Up and Initialization; What’s Nonvolatile and What’s Not

The above table is grouped into nonvolatile and nonvolatile.

All *parameters*, including Threshold, Hysteresis, and Magnet Temperature Compensation, are nonvolatile so they can be set once via I²C, then used without a microcontroller.

Measured and calculated *data* such as magnetic field and temperature are indeterminate until the first readings after power-up.

The default memory address is not preserved after power-down, and defaults to 0 (calibrated magnetic field). The active address remains until it is changed, so multiple reads of the same address do not require writing the address before each read.

DOUT is not saved but initializes in the low field state. This ensures it will not be “latched” initially when used in the latching mode.

Digital Filter

The digital filter is an Infinite impulse response (IIR), weighted running average filter, where the filtered output is calculated as follows:

$$H_n = \frac{1}{m} H + \frac{m-1}{m} H_{n-1}$$

Where H = is the measured magnetic field; H_n = the filtered magnetic field; H_{n-1} is the previous value of the filtered magnetic field; and m is a constant that determines the cutoff frequency as described later.

The time-domain response is exponential, as shown below for a step change in magnetic field:

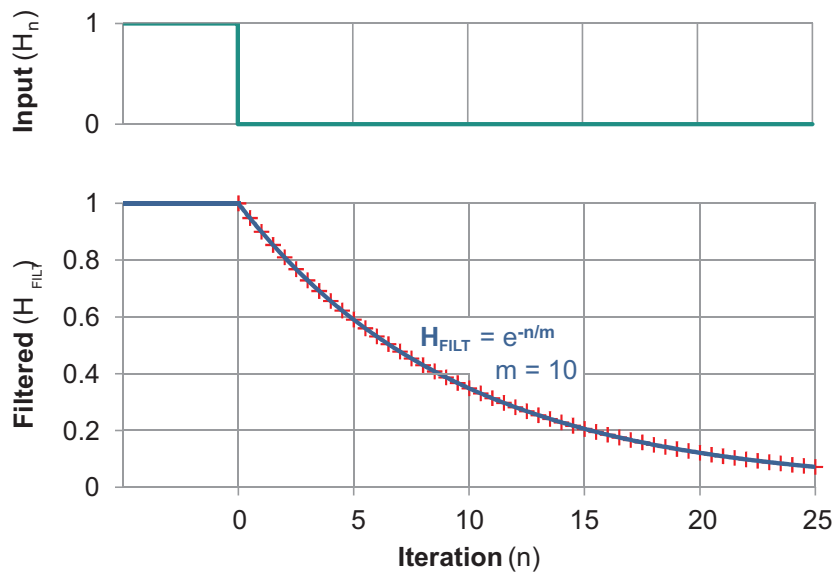

Figure 10. Digital filter time-domain response.

The filter provides a first-order response in the frequency domain:

$$f_{\text{CUTOFF}} = f_{\text{SAMPLE}} / (2\pi m)$$

Where f_{CUTOFF} is the filter cutoff frequency and f_{SAMPLE} is the sensor sampling rate (typically 10 kSps).

So for example, if m = 16, the cutoff frequency is approximately 200 Hz.

m=0 or m=1 disables filter so the output will simply be updated with each sample.

Application Circuits

Microcontroller Interface

A typical microcontroller interface is shown below:

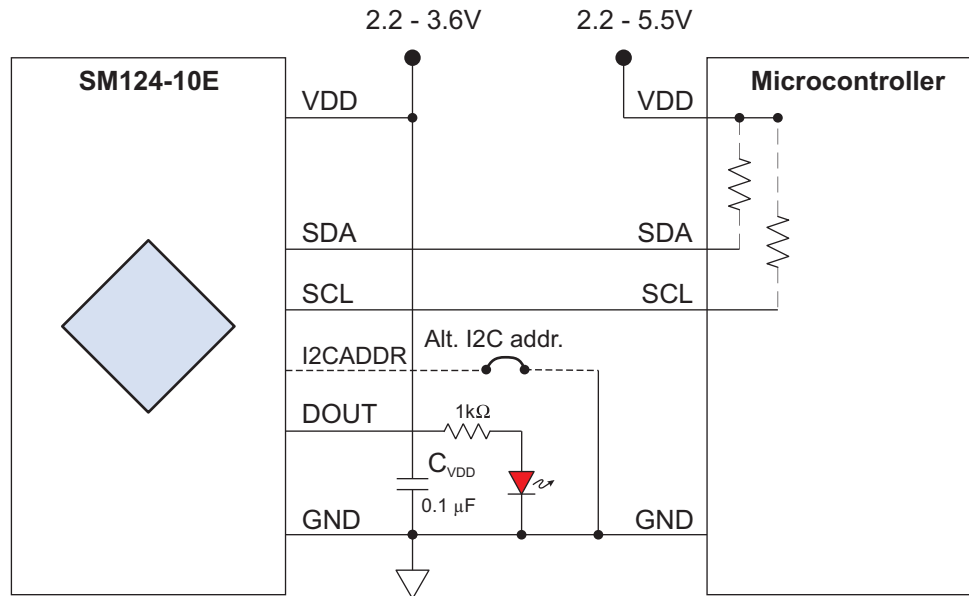

Figure 11. Typical microcontroller connections.

The SM124 is configured as a Slave and the microcontroller should be configured as the Master. The I²C interface is compatible with 3.3 or five-volt microcontrollers.

The SCL and SDA lines are open-drain, so the microcontroller's internal pull-up resistors should be activated in software. External resistors can be used to maximize rise time for high-speed I²C operation, or to preserve I²C speed if there are multiple slaves or a multi-master configuration adding bus capacitance. If external pull-ups are used with different power supplies, they should be connected to the lower supply voltage. A typical external pull-up resistors value is 10 kΩ. If I²C speed is not critical, the effects of bus capacitance can be overcome by slowing the I²C speed.

The I2CADDR pin can be left unconnected for the default I²C address (72 decimal/48 hex), or the pin can be ground to select an alternate address of address (16 decimal/10 hex) of seven alternate I²C addresses.

V_{DD} should be bypassed with a 0.1 μF capacitor placed as close as possible to the V_{DD} and GND pins.

An LED can be used to indicate the digital output. The appropriate series resistor depends on the supply voltage and LED type. A high-efficiency LED will operate over the sensor's entire 2.2 to 3.6V supply range with the 1 KΩ resistor, although its brightness will change with the supply voltage.

Overcurrent Protection

The sensor's digital output can be used as a "virtual circuit breaker" for overcurrent protection of a load such as a DC motor:

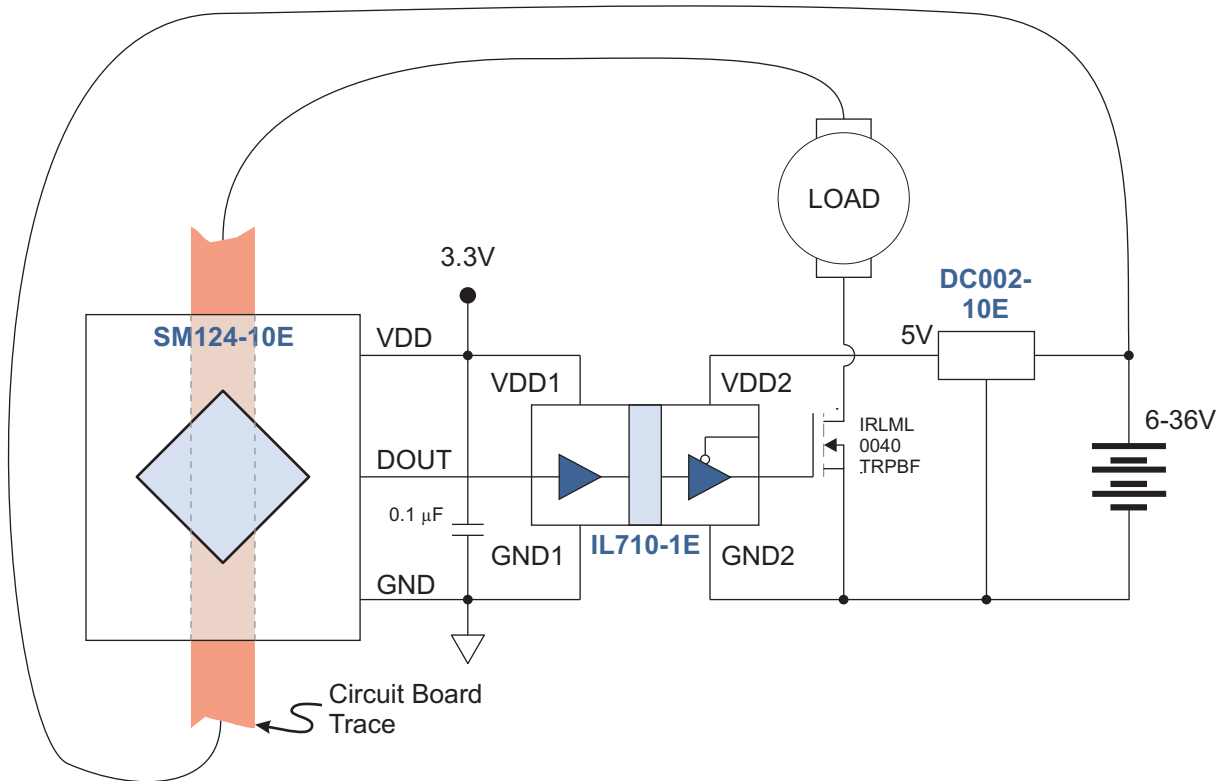

Figure 12. Typical overcurrent protection circuit.

The IL710-1E is an ultraminiature (MSOP8) data coupler that isolates the controller power from the load power. The DC002-10E is a high-voltage tolerant, five-volt regulator to power the gate drive. The power MOSFET has 4.5 volt drive voltage and 3.6 amp and 40 volt drain-to-source voltage capability. The sensor is located over a trace that carries current to the motor.

In this configuration, DOUT_invert is set to 1 to invert DOUT so that the output goes LOW for overcurrent. *Hysteresis* is set to 255 (dec) to invoke the latching mode where DOUT latches ON if the current exceeds the threshold. The output can be reset by via I²C or by cycling the sensor power.

If the field generated by the motor current exceeds the sensor's threshold, DOUT goes LOW, the isolator output also goes LOW, the MOSFET turns off, and power is removed from the load.

The SM124's high sample rate ensures rapid detection of an overcurrent condition. But unlike shunt resistor-based circuits, there are virtually no losses associated with current sensing, and the controller can be electrically isolated from the motor for less noise and more safety.

The SM124 can also drive solid-state relays rather than the isolator and MOSFET in Figure 12. Relays are normally connected from DOUT to VDD to take advantage of the output's high output sink capability. Relays with three-volt "Must Turn On Voltage" and fairly high input impedance can be driven directly by the sensor output.

Illustrative Microcontroller Code

```
/******  
Reads an out-of the-box SM124-10E Smart Position sensor with an Arduino Uno and outputs the  
calibrated magnetic field to the serial port and an analog output.  
I2C SDA on Arduino A4; SCL on A5; analog output on A9.  
*****/  
  
#include <Wire.h> //I2C library  
int field; //Magnetic field (0-100 corresponds to 0-10 Oe)  
  
void setup() {  
  Serial.begin(9600); //Initialize serial communication at 9.6 kbps  
  Wire.begin(); //Join I2C bus as Master  
}  
  
void loop() {  
  Wire.requestFrom(36,1); //Request one byte from the SM124 (I2C addr. 72 shifted right 1 bit)  
  field = Wire.read(); //Read sensor (data always valid so a "While" loop isn't needed)  
  Serial.println(field); //Print on Arduino serial port  
  analogWrite(9, field); //Send as analog output to pin 9  
  delay(500); //Two samples per second  
}
```

```
/******  
Sets an SM124-10E threshold via an Arduino Uno. I2C SDA on A4; SCL on A5.  
*****/  
#include <Wire.h> //I2C Library  
const unsigned char thresholdAddress = 0x20; //Sensor digital threshold  
const unsigned char hysteresisAddress = 0x21; //Magnetic threshold differential  
  
const unsigned char threshold = 100; //Threshold (100 = 10 Oe)  
const unsigned char hysteresis = 10; // hysteresis (10 = 1 Oe)  
  
void setup() {  
  Wire.begin(); //Join I2C bus as Master  
  Wire.beginTransmission(36); //Transmit to I2C addr 72 shifted right 1 bit (SM124 default)  
  Wire.write(thresholdAddress); //Set Sensor active memory address to digital threshold  
  Wire.write(threshold); //Send threshold data  
  Wire.write(hysteresisAddress); //Set Sensor address to hysteresis  
  Wire.write(hysteresis); //Send hysteresis data  
  Wire.endTransmission();  
  delay(15); //Allow parameters to be written to nonvolatile nmemory before proceeding  
}  
  
void loop() {  
}
```

Evaluation Kit

Smart Current Sensor Evaluation Kit

This simple board includes an SM124-10E Smart Magnetometer, a microcontroller that interfaces to the SM124 via I²C, and interfaces to a PC via USB. The sensor can be activated with a magnet or an on-board current trace. A PC-based user interface provides two-way communication with the sensor to display the sensor outputs and allowing field calibration.

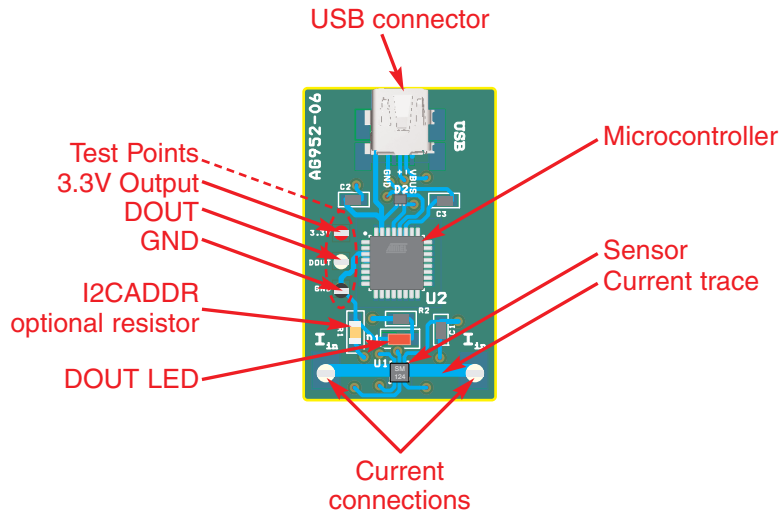

Figure 13. AG952-07E: Smart Current Sensor Evaluation Kit board
1" x 1.625" (25 mm x 41 mm)
(actual size)

Bare Circuit Board

The AG035-06 bare circuit board provides easy connections to TDFN6 devices such as the SM124-10E:



Figure 14. AG035-06 bare circuit board
1.57" x 0.25" (40 mm x 6 mm) TDFN6
(actual size)

2.5 x 2.5 mm TDFN6 Package

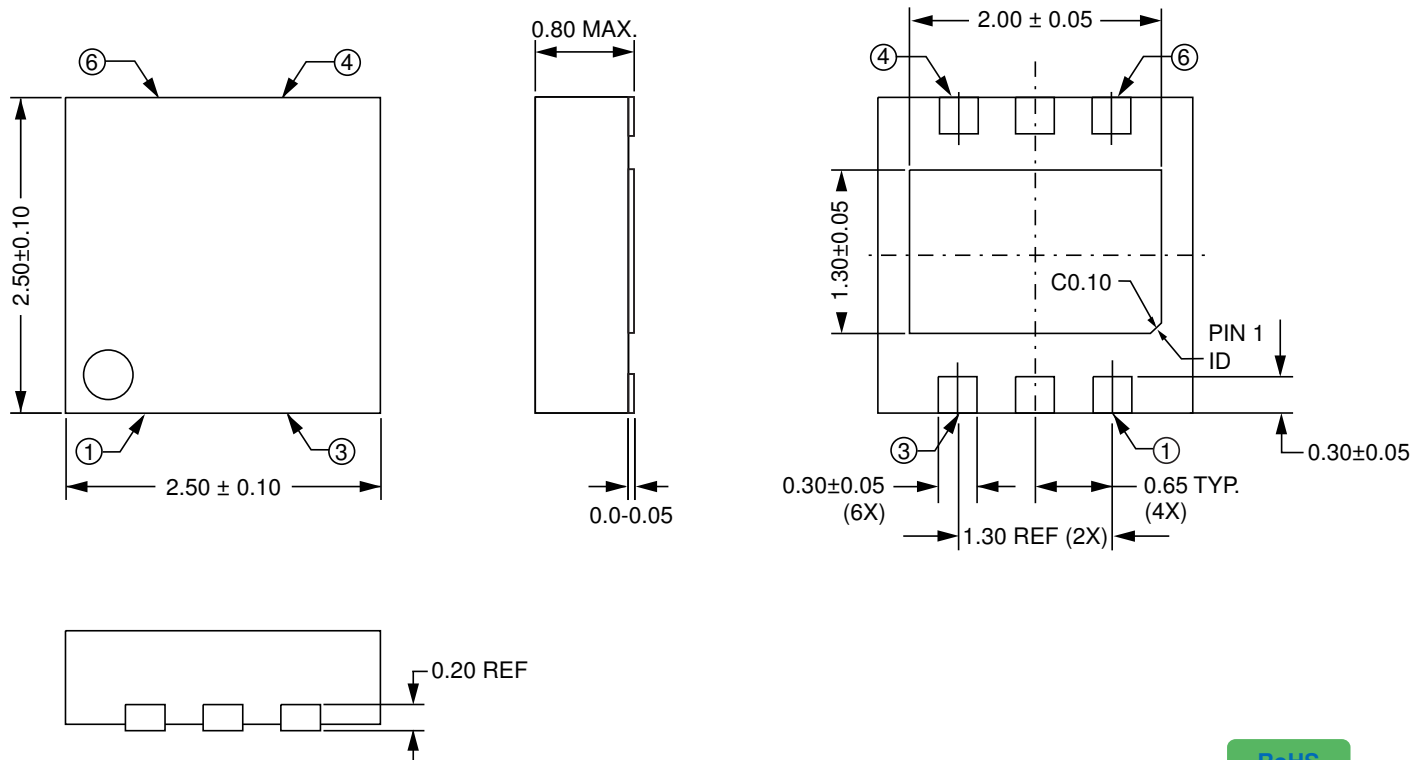

Pin	Symbol	Description
1	I2CADDR	Optional I ² C address select (input)
2	DOUT	Digital Output (CMOS output; default HIGH if above threshold)
3	GND	V _{ss} /Ground
4	VCC	Power Supply (2.2 to 3.6V)
5	SDA	I ² C Data (bidirectional; open drain)
6	SCL	I ² C Clock (input)

Notes:

- Dimensions in millimeters.
- Soldering profile per JEDEC J-STD-020C, MSL 1.

Ordering Information

SM124-10E - 10E TR13

SM = Product Family (Smart Magnetometers)

1 = GMR element with 1 byte data

2 = Magnetic Orientation (cross-axis, i.e., sensitive to a field vector in the pin 2 / pin 5 direction)

4 = Magnetic Field Linear Range (0 to 10 Oe / 0 to 1 mT)

10 = Part Package (2.5 x 2.5 mm TDFN6 package)

E = RoHS compliant (Pb-free)

Bulk Packaging

TR13 = 13" Tape and Reel

Available Parts

Part	Linear Range	Package Marking
SM124-10E	10 Oe (1 mT)	CCBe

Revision History

SB-00-075-Prototype

December 2018

Change

- Updated specifications for prototype.
- Deleted high-field version (SM125).

SB-00-075-PRELIM-A

September 2018

Change

- Updated specifications.
- Initial release.

SB-00-075-PRELIM

June 2018

Change

- Preliminary release.

Datasheet Limitations

The information and data provided in datasheets shall define the specification of the product as agreed between NVE and its customer, unless NVE and customer have explicitly agreed otherwise in writing. All specifications are based on NVE test protocols. In no event however, shall an agreement be valid in which the NVE product is deemed to offer functions and qualities beyond those described in the datasheet.

Limited Warranty and Liability

Information in this document is believed to be accurate and reliable. However, NVE does not give any representations or warranties, expressed or implied, as to the accuracy or completeness of such information and shall have no liability for the consequences of use of such information.

In no event shall NVE be liable for any indirect, incidental, punitive, special or consequential damages (including, without limitation, lost profits, lost savings, business interruption, costs related to the removal or replacement of any products or rework charges) whether or not such damages are based on tort (including negligence), warranty, breach of contract or any other legal theory.

Right to Make Changes

NVE reserves the right to make changes to information published in this document including, without limitation, specifications and product descriptions at any time and without notice. This document supersedes and replaces all information supplied prior to its publication.

Use in Life-Critical or Safety-Critical Applications

Unless NVE and a customer explicitly agree otherwise in writing, NVE products are not designed, authorized or warranted to be suitable for use in life support, life-critical or safety-critical devices or equipment. NVE accepts no liability for inclusion or use of NVE products in such applications and such inclusion or use is at the customer's own risk. Should the customer use NVE products for such application whether authorized by NVE or not, the customer shall indemnify and hold NVE harmless against all claims and damages.

Applications

Applications described in this datasheet are illustrative only. NVE makes no representation or warranty that such applications will be suitable for the specified use without further testing or modification.

Customers are responsible for the design and operation of their applications and products using NVE products, and NVE accepts no liability for any assistance with applications or customer product design. It is customer's sole responsibility to determine whether the NVE product is suitable and fit for the customer's applications and products planned, as well as for the planned application and use of customer's third party customers. Customers should provide appropriate design and operating safeguards to minimize the risks associated with their applications and products.

NVE does not accept any liability related to any default, damage, costs or problem which is based on any weakness or default in the customer's applications or products, or the application or use by customer's third party customers. The customer is responsible for all necessary testing for the customer's applications and products using NVE products in order to avoid a default of the applications and the products or of the application or use by customer's third party customers. NVE accepts no liability in this respect.

Limiting Values

Stress above one or more limiting values (as defined in the Absolute Maximum Ratings System of IEC 60134) will cause permanent damage to the device. Limiting values are stress ratings only and operation of the device at these or any other conditions above those given in the recommended operating conditions of the datasheet is not warranted. Constant or repeated exposure to limiting values will permanently and irreversibly affect the quality and reliability of the device.

Terms and Conditions of Sale

In case an individual agreement is concluded only the terms and conditions of the respective agreement shall apply. NVE hereby expressly objects to applying the customer's general terms and conditions with regard to the purchase of NVE products by customer.

No Offer to Sell or License

Nothing in this document may be interpreted or construed as an offer to sell products that is open for acceptance or the grant, conveyance or implication of any license under any copyrights, patents or other industrial or intellectual property rights.

Export Control

This document as well as the items described herein may be subject to export control regulations. Export might require a prior authorization from national authorities.

Automotive Qualified Products

Unless the datasheet expressly states that a specific NVE product is automotive qualified, the product is not suitable for automotive use. It is neither qualified nor tested in accordance with automotive testing or application requirements. NVE accepts no liability for inclusion or use of non-automotive qualified products in automotive equipment or applications.

In the event that customer uses the product for design-in and use in automotive applications to automotive specifications and standards, customer (a) shall use the product without NVE's warranty of the product for such automotive applications, use and specifications, and (b) whenever customer uses the product for automotive applications beyond NVE's specifications such use shall be solely at customer's own risk, and (c) customer fully indemnifies NVE for any liability, damages or failed product claims resulting from customer design and use of the product for automotive applications beyond NVE's standard warranty and NVE's product specifications.

An ISO 9001 Certified Company

NVE Corporation
11409 Valley View Road
Eden Prairie, MN 55344-3617 USA
Telephone: (952) 829-9217
www.nve.com
e-mail: sensor-info@nve.com

©NVE Corporation
All rights are reserved. Reproduction in whole or in part is prohibited without the prior written consent of the copyright owner.

SB-00-075_SM124-10E

December 2018