

Isolated RS485 Interface

Functional Diagram

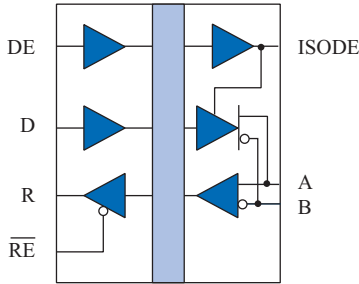

IL485

$V_{ID} (A-B)$	DE	\overline{RE}	ISODE	R	D	Mode
$\geq 200 \text{ mV}$	L	L	L	H	X	Receive
$\leq -200 \text{ mV}$	L	L	L	L	X	Receive
$-7 < V_{ID} < 12$	X	H	X	Z	X	Receive/Drive
$\geq 1.5 \text{ V}$	H	L	H	H	H	Drive
$\leq -1.5 \text{ V}$	H	L	H	L	L	Drive
Open	L	L	L	H	X	Indeterminate

H = High Level, L = Low Level
X = Irrelevant, Z = High Impedance

Features

- 3.3 V Input Supply Compatible
- 2500 V_{RMS} Isolation
- 25 ns Maximum Propagation Delay
- 35 Mbps Data Rate
- 1 ns Pulse Skew (typ.)
- Designed for Multi-point Transmission on Long Bus Lines in Noisy Environments
- $\pm 60 \text{ mA}$ Driver Output Capability
- Thermal Shutdown Protection
- Meets or Exceeds ANSI RS-485 and ISO 8482:1987(E)
- Low EMC Footprint
- -40°C to $+85^\circ\text{C}$ Operating Temperature
- PROFIBUS Compliant
- 16-Pin Wide-Body SOIC Package
- VDE V 0884-10 certified and UL1577 approved

Applications

- RS-485 Systems
- PROFIBUS
- Multiple Data Point Transmission

Description

The IL485 is a galvanically isolated, high-speed differential bus transceiver, designed for bidirectional data communication on balanced transmission lines. The devices use NVE's patented* IsoLoop spintronic Giant Magnetoresistance (GMR) technology. The IL485 was the first isolated RS-485 interface in a standard 16-pin SOIC package to meet the ANSI Standards EIA/TIA-422-B and RS-485.

The IL485 has current limiting and thermal shutdown features to protect against output short circuits and bus contention situations that could cause excessive power dissipation.

Absolute Maximum Ratings⁽¹⁾

Parameters	Symbol	Min.	Typ.	Max.	Units	Test Conditions
Storage Temperature	T_s	-65		150	°C	
Ambient Operating Temperature	T_A	-40		100	°C	
Voltage Range at A or B Bus Pins		-7		12	V	
Supply Voltage ⁽¹⁾	V_{DD1}, V_{DD2}	-0.5		7	V	
Digital Input Voltage		-0.5		$V_{DD} + 0.5$	V	
Digital Output Voltage		-0.5		$V_{DD} + 1$	V	
Continuous Total Power Dissipation				725 377	mW	25°C 85°C
Maximum Output Current	I_O			95	mA	
Lead Solder Temperature				260	°C	10 sec.
ESD			2		kV	HBM

Recommended Operating Conditions

Parameters	Symbol	Min.	Typ.	Max.	Units	Test Conditions
Supply Voltage	V_{DD1} V_{DD2}	3.0 4.5		5.5 5.5	V	
Input Voltage at any Bus Terminal (separately or common mode)	V_I V_{IC}			12 -7	V	
High-Level Digital Input Voltage	V_{IH}	2.4 3.0		V_{DD1}	V	$V_{DD1} = 3.3\text{ V}$ $V_{DD1} = 5.0\text{ V}$
Low-Level Digital Input Voltage	V_{IL}	0		0.8	V	
Differential Input Voltage ⁽²⁾	V_{ID}			+12/-7	V	
High-Level Output Current (Driver)	I_{OH}			60	mA	
High-Level Digital Output Current (Receiver)	I_{OH}			8	mA	
Low-Level Output Current (Driver)	I_{OL}	-60			mA	
Low-Level Digital Output Current (Receiver)	I_{OL}	-8			mA	
Ambient Operating Temperature	T_A	-40		85	°C	
Transient Immunity		20			kV/μs	
Digital Input Signal Rise and Fall Times	t_{IR}, t_{IF}			DC Stable		

Insulation Specifications

Parameters	Symbol	Min.	Typ.	Max.	Units	Test Conditions
Creepage Distance		8.08				mm
Barrier Impedance			$>10^{14} \parallel 7$			$\Omega \parallel \text{pF}$
Leakage Current			0.2		μA	240 V_{RMS} , 60 Hz

Safety and Approvals

VDE V 0884-10 (Basic Isolation; VDE File Number 5016933-4880-0001)

- Working Voltage (V_{IORM}) 600 V_{RMS} (848 V_{PK}); basic insulation; pollution degree 2
- Isolation voltage (V_{ISO}) 2500 V_{RMS}
- Transient overvoltage (V_{IOTM}) 4000 V_{PK}
- Surge rating 4000 V
- Each part tested at 1590 V_{PK} for 1 second, 5 pC partial discharge limit
- Samples tested at 4000 V_{PK} for 60 sec.; then 1358 V_{PK} for 10 sec. with 5 pC partial discharge limit

Safety-Limiting Values	Symbol	Value	Units
Safety rating ambient temperature	T_S	180	°C
Safety rating power (180°C)	P_S	270	mW
Supply current safety rating (total of supplies)	I_S	54	mA

IEC 61010-1 (Edition 2; TUV Certificate Numbers N1502812; N1502812-101)

- Reinforced Insulation; Pollution Degree II; Material Group III
- Working Voltage 300 V_{RMS}

UL 1577 (Component Recognition Program File Number E207481)

- Each part tested at 3000 V_{RMS} (4243 V_{PK}) for 1 second
- Each lot sample tested at 2500 V_{RMS} (3536 V_{PK}) for 1 minute

Soldering Profile

Per JEDEC J-STD-020C, MSL-1

IL485 Pin Connections

1	V _{DD1}	Input Power Supply
2	GND ₁	Input Power Supply Ground*
3	R	Output Data from Bus
4	\overline{RE}	Read Data Enable (if RE is high, R = high impedance)
5	DE	Drive Enable
6	D	Data Input to Bus
7	NC	No Internal Connection
8	GND ₁	Input Power Supply Ground*
9	GND ₂	Output Power Supply Ground*
10	ISODE	Isolated DE Output for use in Profibus applications where the state of the isolated drive enable node needs to be monitored
11	NC	No Internal Connection
12	A	Non-inverting Bus Line
13	B	Inverting Bus Line
14	NC	No Internal Connection
15	GND ₂	Output Power Supply Ground*
16	V _{DD2}	Output Power Supply

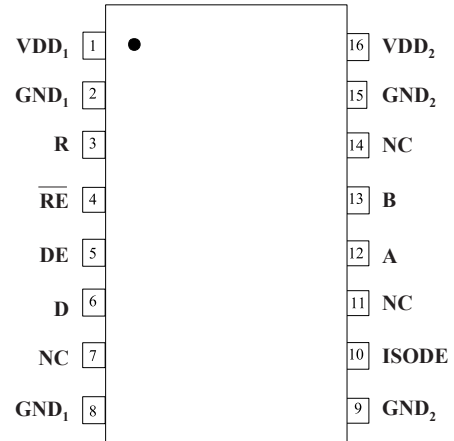

*NOTE: Pins 2 and 8 are internally connected, as are pins 9 and 15.

Driver Section

Electrical Specifications are T_{min} to T_{max} and $V_{DD} = 4.5\text{ V to }5.5\text{ V}$, unless otherwise stated.

Parameters	Symbol	Min.	Typ. ⁽⁵⁾	Max.	Units	Test Conditions
Input Clamp Voltage	V_{IK}			-1.5	V	$I_L = -18\text{ mA}$
Output voltage	V_O	0		6	V	$I_O = 0$
Differential Output Voltage ⁽²⁾	$ V_{OD1} $	1.5		6	V	$I_O = 0$
Differential Output Voltage ⁽²⁾	$ V_{OD2} $	1.5	2.5	5	V	$R_L = 54\ \Omega, V_{DD} = 5\text{ V}$
Differential Output Voltage ⁽²⁾⁽⁶⁾	V_{OD3}	1.5		5	V	$R_L = 54\ \Omega, V_{DD} = 4.5\text{ V}$
Change in Magnitude of Differential Output Voltage ⁽⁷⁾	$\Delta V_{OD} $			± 0.2	V	$R_L = 54\ \Omega$ or $100\ \Omega$
Common Mode Output Voltage	V_{OC}			3 -1	V	$R_L = 54\ \Omega$ or $100\ \Omega$
Change in Magnitude of Common Mode Output Voltage ⁽⁷⁾	$\Delta V_{OC} $			± 0.2	V	$R_L = 54\ \Omega$ or $100\ \Omega$
Output Current ⁽⁴⁾ <i>Output Disabled</i>	I_O			1 -0.8	mA	$V_O = 12\text{ V}$ $V_O = -7\text{ V}$
High Level Input Current	I_{IH}			10	μA	$V_I = 3.5\text{ V}$
Low Level Input Current	I_{IL}			-10	μA	$V_I = 0.4\text{ V}$
Short-circuit Output Current	I_{OS}			250 -150 -250	mA	$V_O = -6\text{ V}$ $V_O = 0\text{ V}$ $V_O = 8\text{ V}$
Supply Current $V_{DD1} = +5\text{ V}$ $V_{DD1} = +3.3\text{ V}$	I_{DD1} I_{DD1}		4 3	6 4	mA	No Load (Outputs Enabled)

Switching Specifications

Parameters	Symbol	Min.	Typ. ⁽⁵⁾	Max.	Units	Test Conditions
Maximum Data Rate		35			Mbps	$R_L = 54\ \Omega, C_L = 50\text{ pF}$
Differential Output Prop Delay	$t_D(\text{OD})$		16	25	ns	$R_L = 54\ \Omega, C_L = 50\text{ pF}$
Pulse Skew ⁽¹⁰⁾	$t_S(\text{P})$		1	6	ns	$R_L = 54\ \Omega, C_L = 50\text{ pF}$
Differential Output Rise & Fall Time	$t_r(\text{OD})$		8	10	ns	$R_L = 54\ \Omega, C_L = 50\text{ pF}$
Output Enable Time To High Level	t_{PZH}		31	65	ns	$R_L = 54\ \Omega, C_L = 50\text{ pF}$
Output Enable Time To Low Level	t_{PZL}		22	35	ns	$R_L = 54\ \Omega, C_L = 50\text{ pF}$
Output Disable Time From High Level	t_{PHZ}		28	50	ns	$R_L = 54\ \Omega, C_L = 50\text{ pF}$
Output Disable Time From Low Level	t_{PLZ}		16	32	ns	$R_L = 54\ \Omega, C_L = 50\text{ pF}$
Skew Limit ⁽³⁾	$t_{SK}(\text{LIM})$		2	12	ns	$R_L = 54\ \Omega, C_L = 50\text{ pF}$

Notes (apply to both driver and receiver sections):

- All voltage values are with respect to network ground except differential I/O bus voltages.
- Differential input/output voltage is measured at the noninverting terminal A with respect to the inverting terminal B.
- Skew limit is the maximum propagation delay difference between any two devices at 25°C .
- The power-off measurement in ANSI Standard EIA/TIA-422-B applies to disabled outputs only and is not applied to combined inputs and outputs.
- All typical values are at $V_{DD1} = 3.3\text{ V}$ or 5 V and $V_{DD2} = 5\text{ V}$, and $T_A = 25^\circ\text{C}$.
- The minimum V_{OD2} with a $100\ \Omega$ load is either $\frac{1}{2} V_{OD1}$ or 2 V , whichever is greater.
- $\Delta|V_{OD}|$ and $\Delta|V_{OC}|$ are the changes in magnitude of V_{OD} and V_{OC} , respectively, that occur when the input is changed from one logic state to the other.
- This applies for both power on and power off, refer to ANSI standard RS-485 for exact condition. The EIA/TIA-422-B limit does not apply for a combined driver and receiver terminal.
- Includes 8 ns read enable time. Maximum propagation delay is 25 ns after read assertion.
- Pulse skew is defined as $|t_{PLH} - t_{PHL}|$ of each channel.
- The relevant test and measurement methods are given in the Electromagnetic Compatibility section on p. 6.
- External magnetic field immunity is improved by this factor if the field direction is “end-to-end” rather than to “pin-to-pin” (see diagram on p. 6).

Receiver Section

Electrical Specifications are T_{min} to T_{max} and $V_{DD} = 4.5\text{ V}$ to 5.5 V , unless otherwise stated.

Parameters	Symbol	Min.	Typ. ⁽⁵⁾	Max.	Units	Test Conditions
Positive-going Input Threshold Voltage	V_{IT+}			0.2	V	$V_o = 2.7\text{ V}$, $I_o = -0.4\text{ mA}$
Negative-going Input Threshold Voltage	V_{IT-}	-0.2			V	$V_o = 0.5\text{ V}$, $I_o = 8\text{ mA}$
Hysteresis Voltage ($V_{IT+} - V_{IT-}$)	V_{HYS}		60		mV	
High Level Digital Output Voltage	V_{OH}	$V_{DD} - 0.2$			V	$V_{ID} = 200\text{ mV}$ $I_{OH} = -20\text{ }\mu\text{A}$
Low Level Digital Output Voltage	V_{OL}			0.2	V	$V_{ID} = -200\text{ mV}$ $I_{OH} = 20\text{ }\mu\text{A}$
High-impedance-state output current	I_{OZ}			± 20	μA	$V_o = 0.4$ to $(V_{DD2} - 0.5)\text{ V}$
Line Input Current ⁽⁸⁾	I_i			1 -0.8	mA	$V_i = 12\text{ V}$ $V_i = -7\text{ V}$ Other Input ⁽¹¹⁾ = 0 V
Input Resistance	r_i	12	20		k Ω	
Supply Current	I_{DD2}		27	34	mA	No load Outputs Enabled

Switching Characteristics at 5 V

Parameters	Symbol	Min.	Typ. ⁽⁵⁾	Max.	Units	Test Conditions
Maximum Data Rate		35			Mbps	$R_L = 54\text{ }\Omega$, $C_L = 50\text{ pF}$
Propagation Delay ^(2, 9)	t_{PD}		24	32	ns	$V_o = -1.5\text{ V}$ to 1.5 V , $C_L = 15\text{ pF}$
Pulse Skew ^(2, 10)	$t_{sk}(P)$		1	6	ns	$V_o = -1.5\text{ V}$ to 1.5 V , $C_L = 15\text{ pF}$
Skew Limit ⁽³⁾	$t_{sk}(LIM)$		2	8	ns	$R_L = 54\text{ }\Omega$, $C_L = 50\text{ pF}$
Output Enable Time To High Level	t_{PZH}		17	24	ns	$C_L = 15\text{ pF}$
Output Enable Time To Low Level	t_{PZL}		30	45	ns	$C_L = 15\text{ pF}$
Output Disable Time From High Level	t_{PHZ}		30	45	ns	$C_L = 15\text{ pF}$
Output Disable Time From Low Level	t_{PLZ}		18	27	ns	$C_L = 15\text{ pF}$

Switching Characteristics at 3.3 V

Parameters	Symbol	Min.	Typ. ⁽⁵⁾	Max.	Units	Test Conditions
Maximum Data Rate		35			Mbps	$R_L = 54\text{ }\Omega$, $C_L = 50\text{ pF}$
Propagation Delay ^(2, 9)	t_{PD}		27	32	ns	$V_o = -1.5\text{ V}$ to 1.5 V , $C_L = 15\text{ pF}$
Pulse Skew ^(2, 10)	$t_{sk}(P)$		2	6	ns	$V_o = -1.5\text{ V}$ to 1.5 V , $C_L = 15\text{ pF}$
Skew Limit ⁽³⁾	$t_{sk}(LIM)$		4	8	ns	$R_L = 54\text{ }\Omega$, $C_L = 50\text{ pF}$
Output Enable Time to High Level	t_{PZH}		20	24	ns	$C_L = 15\text{ pF}$
Output Enable Time to Low Level	t_{PZL}		33	45	ns	$C_L = 15\text{ pF}$
Output Disable Time from High Level	t_{PHZ}		33	45	ns	$C_L = 15\text{ pF}$
Output Disable Time from Low Level	t_{PLZ}		20	27	ns	$C_L = 15\text{ pF}$

Magnetic Field Immunity⁽¹¹⁾

Magnetic Field Immunity at 5 V

Power Frequency Magnetic Immunity	H_{PF}		3500		A/m	50Hz/60Hz
Pulse Magnetic Field Immunity	H_{PM}		4500		A/m	$t_p = 8\text{ }\mu\text{s}$
Damped Oscillatory Magnetic Field	H_{OSC}		4500		A/m	0.1Hz – 1MHz
Cross-axis Immunity Multiplier ⁽¹²⁾	K_X		2.5			

Magnetic Field Immunity at 3.3 V

Power Frequency Magnetic Immunity	H_{PF}		1500		A/m	50Hz/60Hz
Pulse Magnetic Field Immunity	H_{PM}		2000		A/m	$t_p = 8\text{ }\mu\text{s}$
Damped Oscillatory Magnetic Field	H_{OSC}		2000		A/m	0.1Hz – 1MHz
Cross-axis Immunity Multiplier ⁽¹²⁾	K_X		2.5			

Application Information

Electrostatic Discharge Sensitivity

This product has been tested for electrostatic sensitivity to the limits stated in the specifications. However, NVE recommends that all integrated circuits be handled with appropriate care to avoid damage. Damage caused by inappropriate handling or storage could range from performance degradation to complete failure.

Electromagnetic Compatibility

The IL485 is fully compliant with generic EMC standards EN50081, EN50082-1 and the umbrella line-voltage standard for Information Technology Equipment (ITE) EN61000. The IsoLoop Isolator’s Wheatstone bridge configuration and differential magnetic field signaling ensure excellent EMC performance against all relevant standards. NVE conducted compliance tests in the categories below:

- EN50081-1
Residential, Commercial & Light Industrial
Methods EN55022, EN55014
- EN50082-2: Industrial Environment
Methods EN61000-4-2 (ESD), EN61000-4-3 (Electromagnetic Field Immunity), EN61000-4-4 (Electrical Transient Immunity), EN61000-4-6 (RFI Immunity), EN61000-4-8 (Power Frequency Magnetic Field Immunity), EN61000-4-9 (Pulsed Magnetic Field), EN61000-4-10 (Damped Oscillatory Magnetic Field)
- ENV50204
Radiated Field from Digital Telephones (Immunity Test)

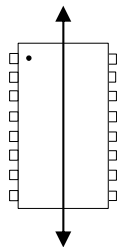

Immunity to external magnetic fields is even higher if the field direction is “end-to-end” rather than to “pin-to-pin” as shown in the diagram below:

Cross-axis Field Direction

Dynamic Power Consumption

IsoLoop Isolators achieve their low power consumption from the way they transmit data across the isolation barrier. By detecting the edge transitions of the input logic signal and converting these to narrow current pulses, a magnetic field is created around the GMR Wheatstone bridge. Depending on the direction of the magnetic field, the bridge causes the output comparator to switch following the input logic signal. Since the current pulses are narrow, about 2.5 ns, the power consumption is independent of mark-to-space ratio and solely dependent on frequency. This has obvious advantages over optocouplers, which have power consumption heavily dependent on frequency and time.

The approximate power supply current per channel is:

$$I_{IN} = 40 \times \frac{f}{f_{MAX}} \times \frac{1}{4} \text{ mA}$$

Where f = operating frequency

$$f_{MAX} = 50 \text{ MHz}$$

Power Supply Decoupling

V_{DD1} and V_{DD2} should be bypassed with Low ESR 47 nF capacitors, placed as close as possible to the V_{DD} pins.

0.3" 16-pin SOIC Package

Dimensions in inches (mm)

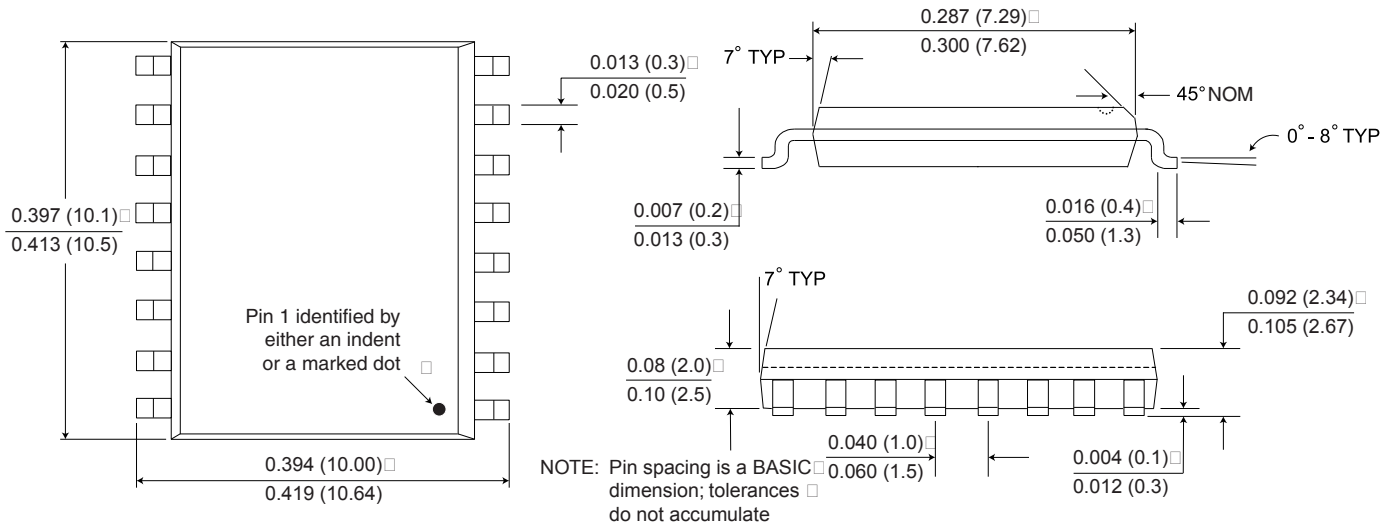

Ordering Information and Valid Part Numbers

IL 485 E TR13

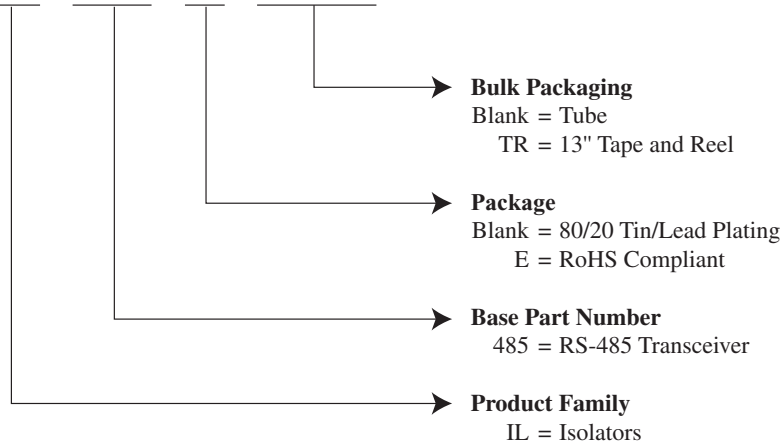

Valid Part Numbers

IL485
IL485E

All IL485 part types are available on tape and reel.



ISB-DS-001-IL485-U
February 2018

Changes

- Updated MSL, agency approvals, magnetic immunity, and misc. wording.

ISB-DS-001-IL485-T

Changes

- Update terms and conditions.

ISB-DS-001-IL485-S

Changes

- Added clarification of internal ground connections (p. 3),

ISB-DS-001-IL485-R

Changes

- Added low EMC footprint.

ISB-DS-001-IL485-Q

Changes

- Added magnetic field immunity and electromagnetic compatibility specifications.
- Added note on package drawing that pin-spacing tolerances are non-accumulating.

ISB-DS-001-IL485-P

Changes

- Changed ordering information to reflect that devices are now fully RoHS compliant with no exemptions.

ISB-DS-001-IL485-O

Changes

- Reorganized supply current specifications; misc. minor changes

ISB-DS-001-IL485-N

Changes

- Eliminated soldering profile chart

ISB-DS-001-IL485-M

Changes

- Updated open input state in truth table

ISB-DS-001-IL485-L

Changes

- Updated package drawing; misc. changes

ISB-DS-001-IL485-K

Changes

- Update UL and IEC approvals

ISB-DS-001-IL485-J

Changes

- Revision letter added.
- Ordering Information Removed.
- IEC 61010-1 “Reinforced Insulation” added.
- Notes added.
- PagIR Soldering Profile added
- Ordering Information added.

Datasheet Limitations

The information and data provided in datasheets shall define the specification of the product as agreed between NVE and its customer, unless NVE and customer have explicitly agreed otherwise in writing. All specifications are based on NVE test protocols. In no event however, shall an agreement be valid in which the NVE product is deemed to offer functions and qualities beyond those described in the datasheet.

Limited Warranty and Liability

Information in this document is believed to be accurate and reliable. However, NVE does not give any representations or warranties, expressed or implied, as to the accuracy or completeness of such information and shall have no liability for the consequences of use of such information.

In no event shall NVE be liable for any indirect, incidental, punitive, special or consequential damages (including, without limitation, lost profits, lost savings, business interruption, costs related to the removal or replacement of any products or rework charges) whether or not such damages are based on tort (including negligence), warranty, breach of contract or any other legal theory.

Right to Make Changes

NVE reserves the right to make changes to information published in this document including, without limitation, specifications and product descriptions at any time and without notice. This document supersedes and replaces all information supplied prior to its publication.

Use in Life-Critical or Safety-Critical Applications

Unless NVE and a customer explicitly agree otherwise in writing, NVE products are not designed, authorized or warranted to be suitable for use in life support, life-critical or safety-critical devices or equipment. NVE accepts no liability for inclusion or use of NVE products in such applications and such inclusion or use is at the customer's own risk. Should the customer use NVE products for such application whether authorized by NVE or not, the customer shall indemnify and hold NVE harmless against all claims and damages.

Applications

Applications described in this datasheet are illustrative only. NVE makes no representation or warranty that such applications will be suitable for the specified use without further testing or modification.

Customers are responsible for the design and operation of their applications and products using NVE products, and NVE accepts no liability for any assistance with applications or customer product design. It is customer's sole responsibility to determine whether the NVE product is suitable and fit for the customer's applications and products planned, as well as for the planned application and use of customer's third party customers. Customers should provide appropriate design and operating safeguards to minimize the risks associated with their applications and products.

NVE does not accept any liability related to any default, damage, costs or problem which is based on any weakness or default in the customer's applications or products, or the application or use by customer's third party customers. The customer is responsible for all necessary testing for the customer's applications and products using NVE products in order to avoid a default of the applications and the products or of the application or use by customer's third party customers. NVE accepts no liability in this respect.

Limiting Values

Stress above one or more limiting values (as defined in the Absolute Maximum Ratings System of IEC 60134) will cause permanent damage to the device. Limiting values are stress ratings only and operation of the device at these or any other conditions above those given in the recommended operating conditions of the datasheet is not warranted. Constant or repeated exposure to limiting values will permanently and irreversibly affect the quality and reliability of the device.

Terms and Conditions of Sale

In case an individual agreement is concluded only the terms and conditions of the respective agreement shall apply. NVE hereby expressly objects to applying the customer's general terms and conditions with regard to the purchase of NVE products by customer.

No Offer to Sell or License

Nothing in this document may be interpreted or construed as an offer to sell products that is open for acceptance or the grant, conveyance or implication of any license under any copyrights, patents or other industrial or intellectual property rights.

Export Control

This document as well as the items described herein may be subject to export control regulations. Export might require a prior authorization from national authorities.

Automotive Qualified Products

Unless the datasheet expressly states that a specific NVE product is automotive qualified, the product is not suitable for automotive use. It is neither qualified nor tested in accordance with automotive testing or application requirements. NVE accepts no liability for inclusion or use of non-automotive qualified products in automotive equipment or applications.

In the event that customer uses the product for design-in and use in automotive applications to automotive specifications and standards, customer (a) shall use the product without NVE's warranty of the product for such automotive applications, use and specifications, and (b) whenever customer uses the product for automotive applications beyond NVE's specifications such use shall be solely at customer's own risk, and (c) customer fully indemnifies NVE for any liability, damages or failed product claims resulting from customer design and use of the product for automotive applications beyond NVE's standard warranty and NVE's product specifications.

An ISO 9001 Certified Company

NVE Corporation
11409 Valley View Road
Eden Prairie, MN 55344-3617 USA
Telephone: (952) 829-9217
www.nve.com
e-mail: iso-info@nve.com

©NVE Corporation
All rights are reserved. Reproduction in whole or in part is prohibited without the prior written consent of the copyright owner.

ISB-DS-001-IL485-U

February 2018