



# REG1117 REG1117A

For most current data sheet and other product information, visit [www.burr-brown.com](http://www.burr-brown.com)

## 800mA and 1A Low Dropout Positive Regulator 1.8V, 2.5V, 2.85V, 3.3V, 5V, and Adjustable

### FEATURES

- FIXED AND ADJUSTABLE VERSIONS
- 2.85V MODEL FOR SCSI-2 ACTIVE TERMINATION
- OUTPUT CURRENT:  
REG1117: 800mA max  
REG1117A: 1A max
- OUTPUT TOLERANCE:  $\pm 1\%$  max
- DROPOUT VOLTAGE:  
REG1117: 1.2V max at  $I_O = 800\text{mA}$   
REG1117A: 1.3V max at  $I_O = 1\text{A}$
- INTERNAL CURRENT LIMIT
- THERMAL OVERLOAD PROTECTION
- SOT-223 AND DDPACK SURFACE MOUNT PACKAGES

### APPLICATIONS

- SCSI-2 ACTIVE TERMINATION
- HAND-HELD DATA COLLECTION DEVICES
- HIGH EFFICIENCY LINEAR REGULATORS
- BATTERY POWERED INSTRUMENTATION
- BATTERY MANAGEMENT CIRCUITS FOR NOTEBOOK AND PALMTOP PCs
- CORE VOLTAGE SUPPLY:  
FPGA, PLD, DSP, CPU

### DESCRIPTION

The REG1117 is a family of easy-to-use three-terminal voltage regulators. The family includes a variety of fixed- and adjustable-voltage versions, two currents (800mA and 1A) and two package types (SOT-223 and DDPACK). See the chart below for available options.

Output voltage of the adjustable versions is set with two external resistors. The REG1117's low dropout voltage allows its use with as little as 1V input-output voltage differential.

Laser trimming assures excellent output voltage accuracy without adjustment. An NPN output stage allows output stage drive to contribute to the load current for maximum efficiency.

VOLTAGE	800mA		1A	
	SOT-223	DDPAK	SOT-223	DDPAK
1.8V			✓	✓
2.5V			✓	✓
2.85V	✓			
3.3V	✓	✓		
5V	✓			✓
Adj.	✓		✓	✓

# SPECIFICATIONS

At  $T_J = +25^\circ\text{C}$ , unless otherwise noted.

PARAMETER	CONDITIONS	REG1117, REG1117A			UNITS
		MIN	TYP	MAX	
<b>OUTPUT VOLTAGE</b>					
REG1117-2.85	$I_O = 10\text{mA}$ , $V_{IN} = 4.85\text{V}$ $I_O = 0$ to $800\text{mA}$ , $V_{IN} = 4.05$ to $10\text{V}$	2.820 2.790	2.85 2.85	2.880 2.910	V
REG1117-3.3	$I_O = 10\text{mA}$ , $V_{IN} = 5.3\text{V}$ $I_O = 0$ to $800\text{mA}$ , $V_{IN} = 4.8$ to $10\text{V}$	3.270 3.240	3.30 3.30	3.330 3.360	V
REG1117-5	$I_O = 10\text{mA}$ , $V_{IN} = 7\text{V}$ $I_O = 0$ to $800\text{mA}$ , $V_{IN} = 6.5$ to $10\text{V}$	4.950 4.900	5.00 5.00	5.050 5.100	V
REG1117A-1.8	$I_O = 10\text{mA}$ , $V_{IN} = 3.8\text{V}$ $I_O = 0$ to $1\text{A}$ , $V_{IN} = 3.8\text{V}$ to $10\text{V}$	1.782 1.764	1.8 1.8	1.818 1.836	V
REG1117A-2.5	$I_O = 10\text{mA}$ , $V_{IN} = 4.5\text{V}$ $I_O = 0$ to $1\text{A}$ , $V_{IN} = 4.5\text{V}$ to $10\text{V}$	2.475 2.450	2.5 2.5	2.525 2.550	V
REG1117A-5	$I_O = 10\text{mA}$ , $V_{IN} = 7\text{V}$ $I_O = 0$ to $1\text{A}$ , $V_{IN} = 7\text{V}$ to $10\text{V}$	4.950 4.900	5.0 5.0	5.050 5.100	V
<b>REFERENCE VOLTAGE</b>					
REG1117 (Adjustable)	$I_O = 10\text{mA}$ , $V_{IN} - V_O = 2\text{V}$ $I_O = 10$ to $800\text{mA}$ , $V_{IN} - V_O = 1.4$ to $10\text{V}$	1.238 1.225	1.250 1.250	1.262 1.280	V
REG1117A (Adjustable)	$I_O = 10\text{mA}$ , $V_{IN} - V_O = 2\text{V}$ $I_O = 10\text{mA}$ to $1\text{A}$ , $V_{IN} - V_O = 1.4$ to $10\text{V}$	1.238 1.225	1.250 1.250	1.262 1.280	V
<b>LINE REGULATION</b>					
REG1117-2.85	$I_O = 0$ , $V_{IN} = 4.25$ to $10\text{V}$		1	7	mV
REG1117-3.3	$I_O = 0$ , $V_{IN} = 4.8$ to $10\text{V}$		2	7	mV
REG1117-5	$I_O = 0$ , $V_{IN} = 6.5$ to $15\text{V}$		3	10	mV
REG1117 (Adjustable)	$I_O = 10\text{mA}$ , $V_{IN} - V_O = 1.5$ to $13.75\text{V}$		0.1	0.4	%
REG1117A (Adjustable)	$I_O = 10\text{mA}$ , $V_{IN} - V_O = 1.5$ to $13.75\text{V}$		0.1	0.4	%
REG1117A-1.8	$I_O = 0$ , $V_{IN} = 3.8\text{V}$ to $10\text{V}$		1	7	mV
REG1117A-2.5	$I_O = 0$ , $V_{IN} = 4.5\text{V}$ to $10\text{V}$		1	7	mV
REG1117A-5.0	$I_O = 0$ , $V_{IN} = 7\text{V}$ to $15\text{V}$		3	10	mV
<b>LOAD REGULATION</b>					
REG1117-2.85	$I_O = 0$ to $800\text{mA}$ , $V_{IN} = 4.25\text{V}$		2	10	mV
REG1117-3.3	$I_O = 0$ to $800\text{mA}$ , $V_{IN} = 4.8\text{V}$		3	12	mV
REG1117-5	$I_O = 0$ to $800\text{mA}$ , $V_{IN} = 6.5\text{V}$		3	15	mV
REG1117 (Adjustable)	$I_O = 10$ to $800\text{mA}$ , $V_{IN} - V_O = 3\text{V}$		0.1	0.4	%
REG1117A (Adjustable)	$I_O = 10\text{mA}$ to $1\text{A}$ , $V_{IN} - V_O = 3\text{V}$		0.1	0.4	%
REG1117A-1.8	$I_O = 0$ to $1\text{A}$ , $V_{IN} = 3.8\text{V}$		2	10	mV
REG1117A-2.5	$I_O = 0$ to $1\text{A}$ , $V_{IN} = 4.5\text{V}$		2	10	mV
REG1117A-5	$I_O = 0$ to $1\text{A}$ , $V_{IN} = 7.0\text{V}$		3	15	mV
<b>DROPOUT VOLTAGE</b>					
All Models	$I_O = 100\text{mA}$		1.00	1.10	V
	$I_O = 500\text{mA}$		1.05	1.15	V
REG1117 Models	$I_O = 800\text{mA}$		1.10	1.20	V
REG1117A	$I_O = 1\text{A}$		1.2	1.30	V
	$I_O = 1\text{A}$		1.2	1.55	V
<b>CURRENT LIMIT</b>					
REG1117 Models	$V_{IN} - V_O = 5\text{V}$	800	950	1200	mA
REG1117A	$V_{IN} - V_O = 5\text{V}$	1000	1250	1600	mA
<b>MINIMUM LOAD CURRENT</b>					
Adjustable Models	$V_{IN} - V_O = 13.75\text{V}$		1.7	5	mA
<b>QUIESCENT CURRENT</b>					
Fixed-Voltage Models	$V_{IN} - V_O = 5\text{V}$		4	10	mA
<b>Adjust Pin Current</b>					
vs Load Current, REG1117	$I_O = 10\text{mA}$ , $V_{IN} - V_O = 1.4$ to $10\text{V}$		50	120	$\mu\text{A}$
vs Load Current, REG1117A	$I_O = 10\text{mA}$ to $800\text{mA}$ , $V_{IN} - V_O = 1.4$ to $10\text{V}$ $I_O = 10\text{mA}$ to $1\text{A}$ , $V_{IN} - V_O = 1.4$ to $10\text{V}$		0.5 0.5	5 5	$\mu\text{A}$ $\mu\text{A}$
<b>THERMAL REGULATION</b>					
All Models	30ms Pulse		0.01	0.1	%/W
<b>RIPPLE REJECTION</b>					
All Models	$f = 120\text{Hz}$ , $V_{IN} - V_{OUT} = 3\text{V} + 1V_{PP}$ Ripple		62		dB
<b>TEMPERATURE DRIFT</b>					
Fixed-Voltage Models	$T_J = 0^\circ\text{C}$ to $+125^\circ\text{C}$		0.5		%
Adjustable Models	$T_J = 0^\circ\text{C}$ to $+125^\circ\text{C}$		2		%

# SPECIFICATIONS (cont.)

At  $T_J = +25^\circ\text{C}$ , unless otherwise noted.

PARAMETER	CONDITIONS	REG1117, REG1117A			UNITS
		MIN	TYP	MAX	
<b>LONG-TERM STABILITY</b> All Models	$T_A = +125^\circ\text{C}$ , 1000Hr		0.3		%
<b>OUTPUT NOISE</b> rms Noise, All Models	$f = 10\text{Hz}$ to 10kHz		0.003		%
<b>THERMAL RESISTANCE</b> Operating Junction Temperature Range		0		+125	$^\circ\text{C}$
Storage Range		-65		+150	$^\circ\text{C}$
Thermal Resistance, $\theta_{JC}$ 3-Lead SOT-223 Surface-Mount	(Junction-to-Case at Tab)		15		$^\circ\text{C}/\text{W}$
3-Lead DDPAK Surface-Mount	$f > 50\text{Hz}$		2		$^\circ\text{C}/\text{W}$
	dc		3		$^\circ\text{C}/\text{W}$
Thermal Resistance, $\theta_{JA}$ 3-Lead DDPAK Surface-Mount	(Junction-to-Case at Tab) No Heat Sink		65		$^\circ\text{C}/\text{W}$

NOTES: (1) Specification applies over the full operating Junction temperature range,  $0^\circ\text{C}$  to  $125^\circ\text{C}$ . (2) REG1117 and REG1117A adjustable versions require a minimum load current for  $\pm 3\%$  regulation. (3) Dropout voltage is the Input voltage minus output voltage that produces a 1% decrease in output voltage. (4) Percentage change in unloaded output voltage before vs after a 30ms power pulse of  $I_O = 800\text{mA}$  (REG1117 models),  $I_O = 1\text{A}$  (REG1117A),  $V_{IN} - V_O = 1.4\text{V}$  (Reading taken 10ms after pulse).

## ABSOLUTE MAXIMUM RATINGS<sup>(1)</sup>

Power Dissipation .....	Internally Limited
Input Voltage .....	15V
Operating Junction Temperature Range .....	$0^\circ\text{C}$ to $+125^\circ\text{C}$
Storage Temperature Range .....	$-65^\circ\text{C}$ to $+150^\circ\text{C}$
Lead Temperature (soldering, 10s) <sup>(2)</sup> .....	$+300^\circ\text{C}$

NOTE: (1) Stresses above these ratings may cause permanent damage. (2) See "Soldering Methods."

## CONNECTION DIAGRAM

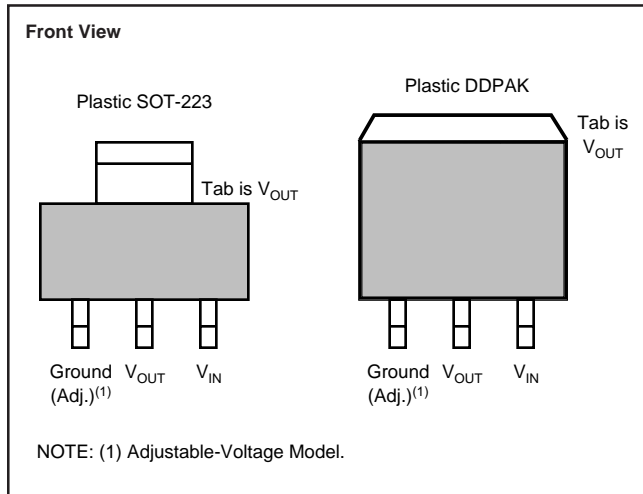

## ELECTROSTATIC DISCHARGE SENSITIVITY

This integrated circuit can be damaged by ESD. Burr-Brown recommends that all integrated circuits be handled with appropriate precautions. Failure to observe proper handling and installation procedures can cause damage.

ESD damage can range from subtle performance degradation to complete device failure. Precision integrated circuits may be more susceptible to damage because very small parametric changes could cause the device not to meet its published specifications.

The information provided herein is believed to be reliable; however, BURR-BROWN assumes no responsibility for inaccuracies or omissions. BURR-BROWN assumes no responsibility for the use of this information, and all use of such information shall be entirely at the user's own risk. Prices and specifications are subject to change without notice. No patent rights or licenses to any of the circuits described herein are implied or granted to any third party. BURR-BROWN does not authorize or warrant any BURR-BROWN product for use in life support devices and/or systems.

## PACKAGE/ORDERING INFORMATION

PRODUCT	V <sub>o</sub> /I <sub>o</sub>	PACKAGE	PACKAGE DRAWING NUMBER	SPECIFIED TEMPERATURE RANGE	PACKAGE MARKING	ORDERING NUMBER <sup>(1)</sup>	TRANSPORT MEDIA
<b>800mA Output</b>							
REG1117-2.85	2.85/800mA "/"	SOT-223	311	-40°C to +85°C	BB11172	REG1117-2.85 REG1117-2.85/2K5	Rails Tape and Reel
REG1117-3.3	3.3/800mA "/"	SOT-223	311	-40°C to +85°C	BB11174	REG1117-3.3 REG1117-3.3/2K5	Rails Tape and Reel
REG1117F-3.3	3.3/800mA "/"	DDPAK-3	339	-40°C to +85°C	BB1117F4	REG1117F-3.3 REG1117F-3.3/500	Rails Tape and Reel
REG1117-5	5V/800mA "/"	SOT-223	311	-40°C to +85°C	BB11175	REG1117-5 REG1117-5/2K5	Rails Tape and Reel
REG1117	Adj./800mA "/"	SOT-223	311	-40°C to +85°C	BB1117	REG1117 REG1117/2K5	Rails Tape and Reel
<b>1A Output</b>						<b>1A Output</b>	
REG1117A-1.8 <sup>(2)</sup>	1.8V/1A "/"	SOT-223	311	-40°C to +85°C	R111718	REG1117A-1.8 REG1117A-1.8/2K5	Rails Tape and Reel
REG1117FA-1.8	1.8/1A "/"	DDPAK-3	339	-40°C to +85°C	REG1117FA1.8	REG1117FA-1.8 REG1117FA-1.8/500	Rails Tape and Reel
REG1117A-2.5 <sup>(2)</sup>	2.5/1A "/"	SOT-223	311	-40°C to +85°C	R111725	REG1117A-2.5 REG1117A-2.5/2K5	Rails Tape and Reel
REG1117FA-2.5	2.5/1A "/"	DDPAK-3	339	-40°C to +85°C	REG1117FA2.5	REG1117FA-2.5 REG1117FA-2.5/500	Rails Tape and Reel
REG1117FA-5	5/1A "/"	DDPAK-3	339	-40°C to +85°C	REG1117FA5.0	REG1117FA-5 REG1117FA-5/500	Rails Tape and Reel
REG1117A	Adj./1A "/"	SOT-223	311	-40°C to +85°C	BB1117A	REG1117A REG1117A/2K5	Rails Tape and Reel
REG1117FA	Adj./1A "/"	DDPAK-3	339	-40°C to +85°C	REG1117FA	REG1117FA REG1117FA/500	Rails Tape and Reel

NOTE: (1) Models with a slash (/) are available only in Tape and Reel in the quantities indicated (e.g., /2K5 indicates 2500 devices per reel). Ordering 2500 pieces of "REG1117/2K5" will get a single 2500-piece Tape and Reel. (2) REG1117A-1.8 and REG1117A-2.5 available Q1-2000.

## SIMPLIFIED SCHEMATIC

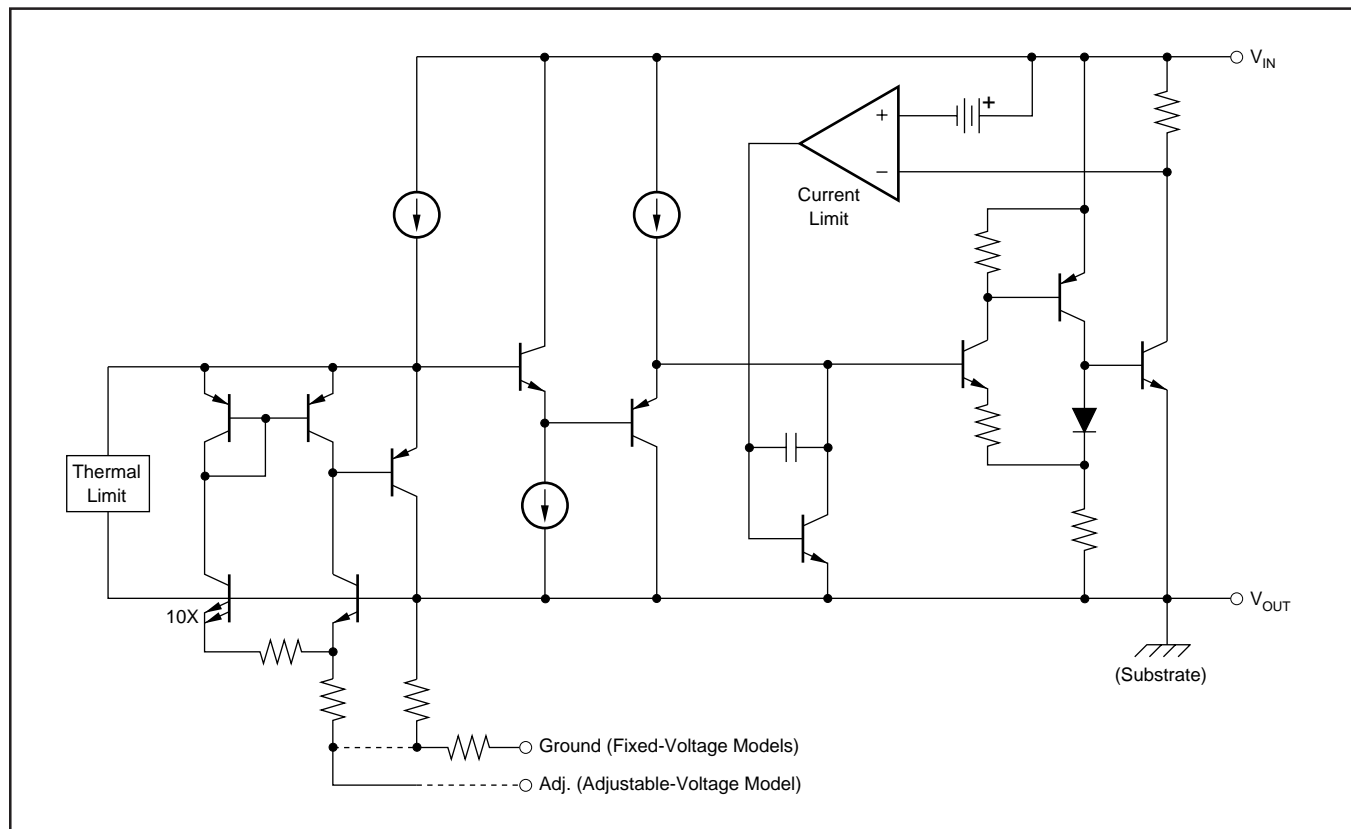

# TYPICAL PERFORMANCE CURVES

At  $T_J = +25^\circ\text{C}$ , all models, unless otherwise specified.

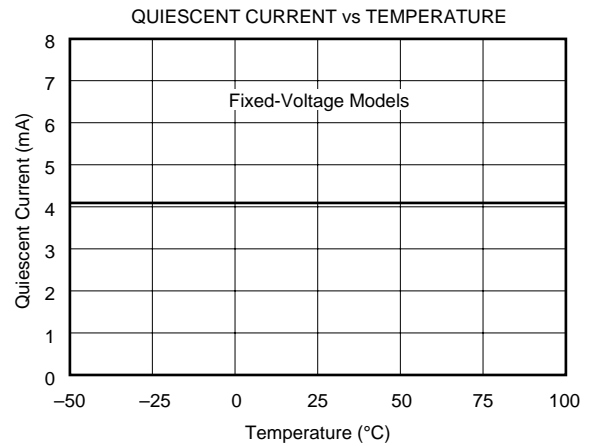
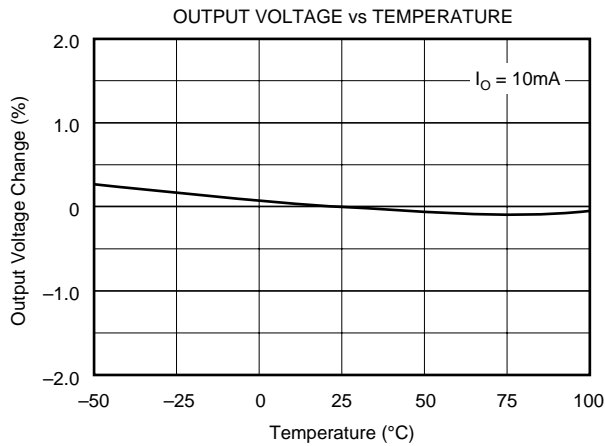
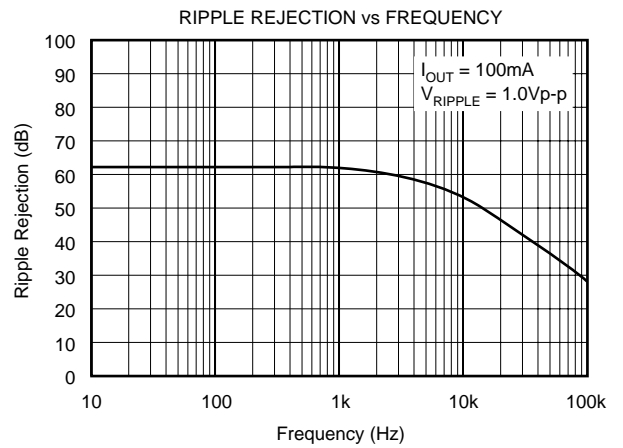
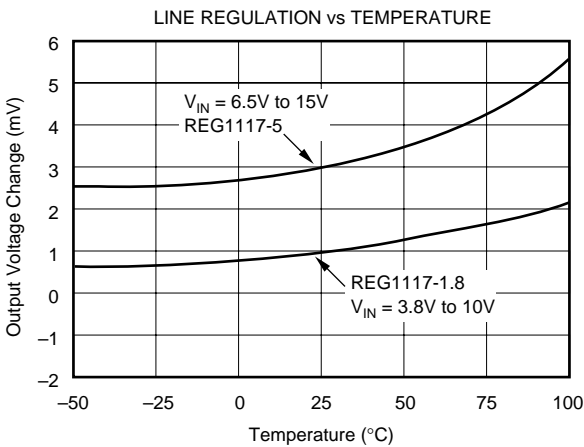
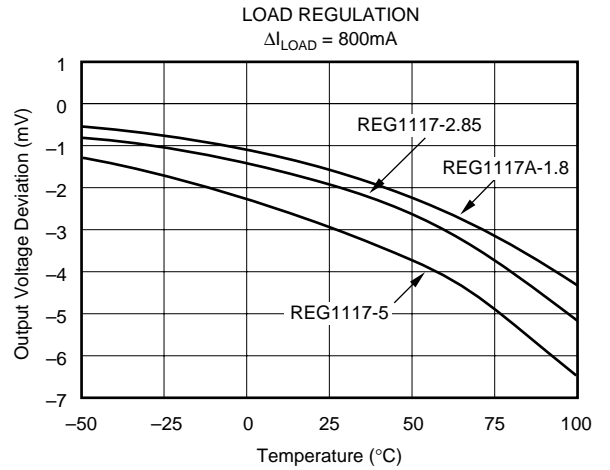
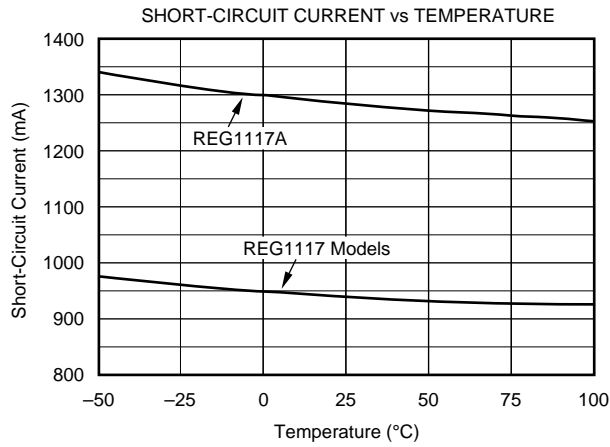

# TYPICAL PERFORMANCE CURVE (cont.)

At  $T_j = +25^\circ\text{C}$ , all models, unless otherwise specified.

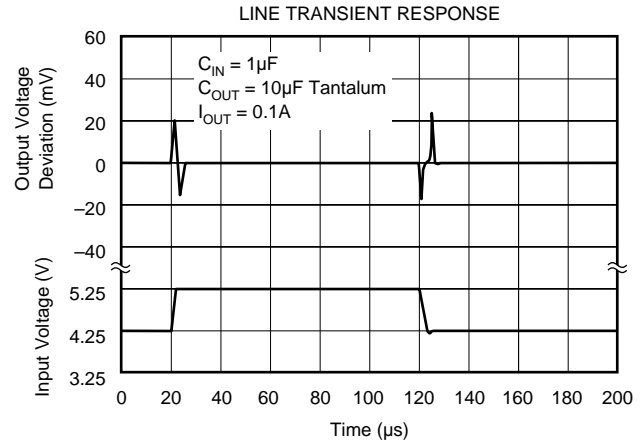
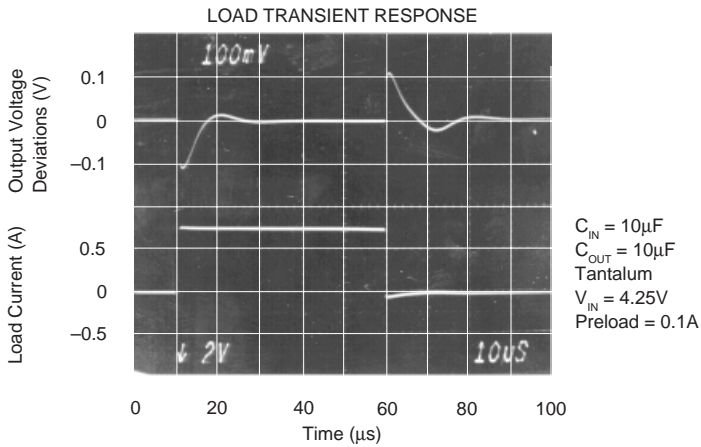

## APPLICATIONS INFORMATION

Figure 1 shows the basic hookup diagram for fixed-voltage models. All models require an output capacitor for proper operation and to improve high frequency load regulation. A  $10\mu\text{F}$  tantalum capacitor is recommended. Aluminum electrolytic types of  $50\mu\text{F}$  or greater can also be used. A high quality capacitor should be used to assure that the ESR (effective series resistance) is less than  $0.5\Omega$ .

Figure 2 shows a hookup diagram for the adjustable voltage model. Resistor values are shown for some commonly used output voltages. Values for other voltages can be calculated from the equation shown in Figure 2. For best load regulation, connect  $R_1$  close to the output pin and  $R_2$  close to the ground side of the load as shown.

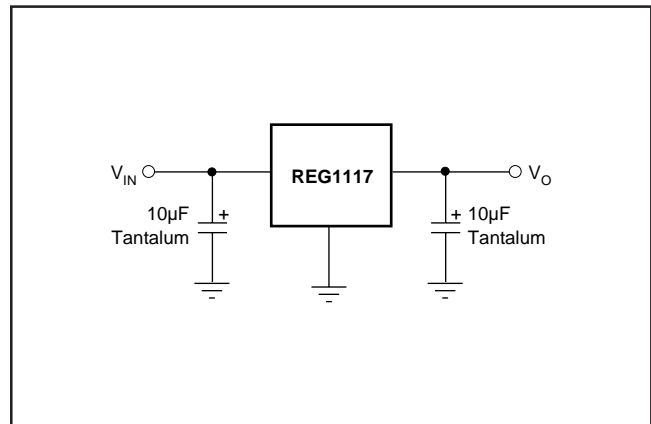

FIGURE 1. Fixed-Voltage Model—Basic Connections.

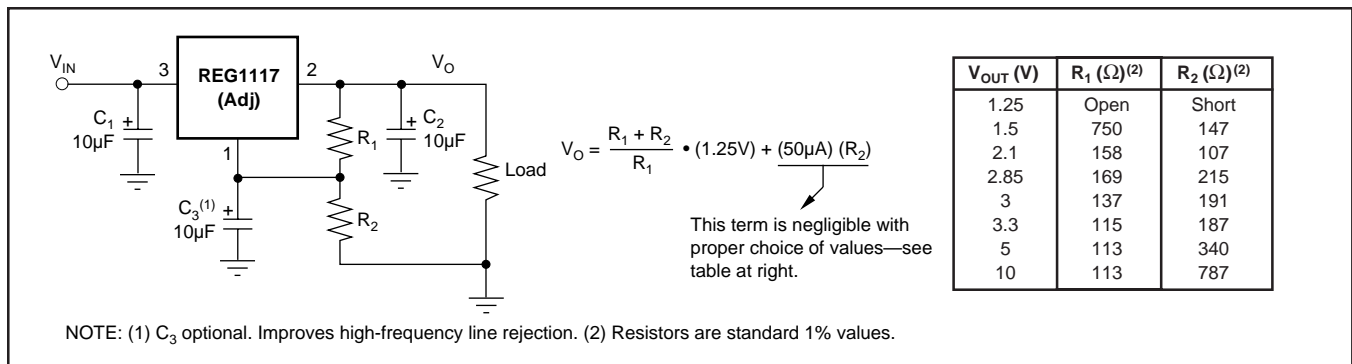

FIGURE 2. Adjustable-Voltage Model—Basic Connections.

## THERMAL CONSIDERATIONS

The REG1117 has current limit and thermal shutdown circuits that protect it from overload. The thermal shutdown activates at approximately  $T_J = 165^\circ\text{C}$ . For continuous operation, however, the junction temperature should not be allowed to exceed  $125^\circ\text{C}$ . Any tendency to activate the thermal shutdown in normal use is an indication of an inadequate heat sink or excessive power dissipation. The power dissipation is equal to:

$$P_D = (V_{IN} - V_{OUT}) I_{OUT}$$

The junction temperature can be calculated by:

$$T_J = T_A + P_D (\theta_{JA})$$

where  $T_A$  is the ambient temperature, and  $\theta_{JA}$  is the junction-to-ambient thermal resistance

A simple experiment will determine whether the maximum recommended junction temperature is exceeded in an actual circuit board and mounting configuration: Increase the ambient temperature above that expected in normal operation

until the device's thermal shutdown is activated. If this occurs at more than  $40^\circ\text{C}$  above the maximum expected ambient temperature, then the  $T_J$  will be less than  $125^\circ\text{C}$  during normal operation.

The internal protection circuitry of the REG1117 was designed to protect against overload conditions. It was not intended to replace proper heat sinking. Continuously running the REG1117 into thermal shutdown will degrade reliability.

## LAYOUT CONSIDERATIONS

The DDPAK (REG1117F-3.3 and REG1117FA) is a surface-mount power package that has excellent thermal characteristics. For best thermal performance, its mounting tab should be soldered directly to a circuit board copper area (see Figure 3). Increasing the copper area improves heat dissipation. Figure 4 shows typical thermal resistance from junction-to-ambient as a function of the copper area.

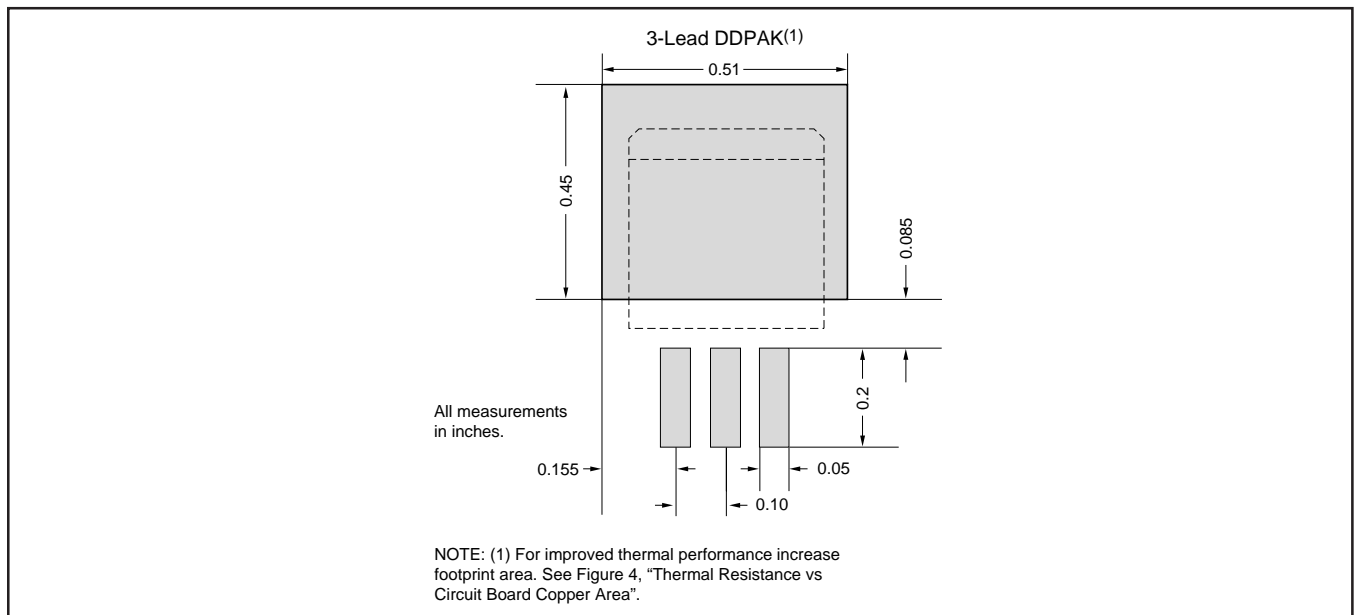

FIGURE 3. DDPAK Thermal Resistance vs Circuit Board Copper Area.

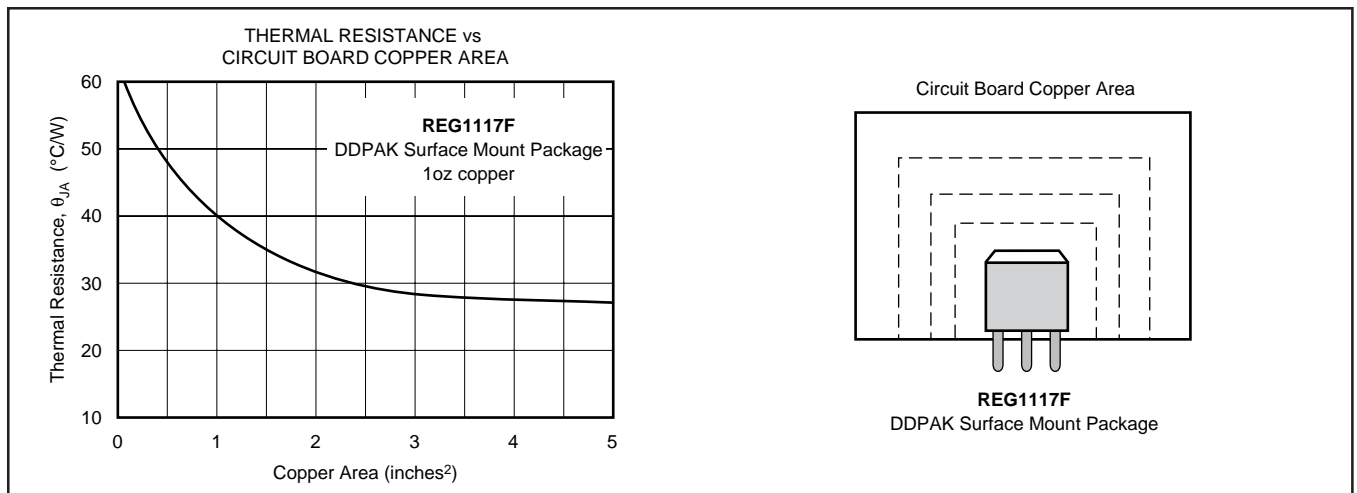

FIGURE 4. DDPAK Thermal Resistance vs Circuit Board Copper Area.

The SOT-223 package derives heat sinking from conduction through its copper leads, especially the large mounting tab. These must be soldered to a circuit board with a substantial amount of copper remaining (see Figure 5). Circuit board traces connecting the tab and the leads should be made as large as practical. The mounting tab of both packages is electrically connected to  $V_{OUT}$ .

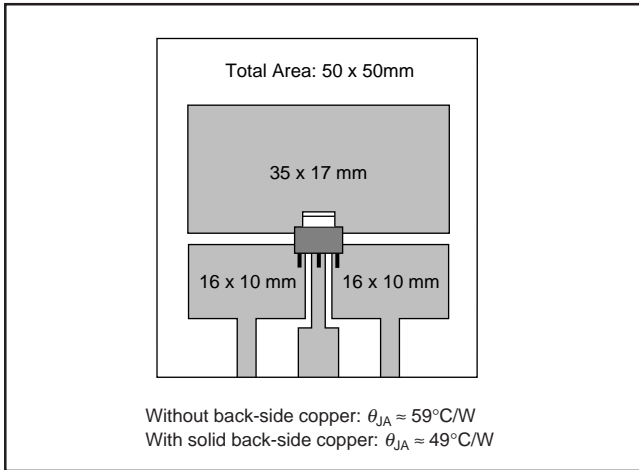

FIGURE 5. SOT-223 Circuit Board Layout Example.

Other nearby circuit traces, including those on the back side of the circuit board, help conduct heat away from the device, even though they may not be electrically connected. Make all nearby copper traces as wide as possible and leave only narrow gaps between traces.

Table I shows approximate values of  $\theta_{JA}$  for various circuit board and copper areas for the SOT-223 package. Nearby heat dissipating components, circuit board mounting conditions and ventilation can dramatically affect the actual  $\theta_{JA}$ . Proper heat sinking significantly increases the maximum power dissipation at a given ambient temperature as shown in Figure 6.

### SOLDERING METHODS

Both REG1117 packages are suitable for infrared reflow and vapor-phase reflow soldering techniques. The high rate of temperature change that occurs with wave soldering, or hand soldering can damage the REG1117.

TOTAL PC BOARD AREA	TOPSIDE <sup>(1)</sup> COPPER AREA	BACKSIDE COPPER AREA	SOT-223 THERMAL RESISTANCE JUNCTION-TO-AMBIENT
2500mm <sup>2</sup>	2500mm <sup>2</sup>	2500mm <sup>2</sup>	46°C/W
2500mm <sup>2</sup>	1250mm <sup>2</sup>	2500mm <sup>2</sup>	47°C/W
2500mm <sup>2</sup>	950mm <sup>2</sup>	2500mm <sup>2</sup>	49°C/W
2500mm <sup>2</sup>	2500mm <sup>2</sup>	0	51°C/W
2500mm <sup>2</sup>	1800mm <sup>2</sup>	0	53°C/W
1600mm <sup>2</sup>	600mm <sup>2</sup>	1600mm <sup>2</sup>	55°C/W
2500mm <sup>2</sup>	1250mm <sup>2</sup>	0	58°C/W
2500mm <sup>2</sup>	915mm <sup>2</sup>	0	59°C/W
1600mm <sup>2</sup>	600mm <sup>2</sup>	0	67°C/W
900mm <sup>2</sup>	340mm <sup>2</sup>	900mm <sup>2</sup>	72°C/W
900mm <sup>2</sup>	340mm <sup>2</sup>	0	85°C/W

NOTE: (1) Tab is attached to the topside copper.

TABLE I.

INSPEC Abstract Number: B91007604, C91012627  
 Kelly, E.G. "Thermal Characteristics of Surface 5WK9Ω Packages." The Proceedings of SMTCON. Surface Mount Technology Conference and Exposition: *Competitive Surface Mount Technology*, April 3-6, 1990, Atlantic City, NJ, USA. Abstract Publisher: IC Manage, 1990, Chicago, IL, USA.

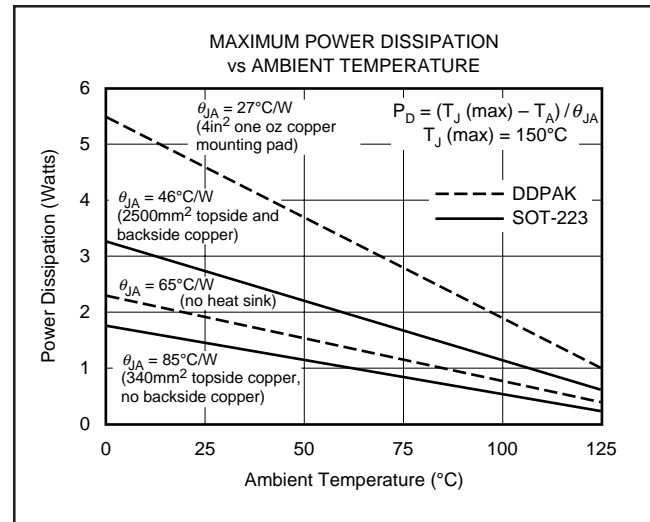

FIGURE 6. Maximum Power Dissipation vs Ambient Temperature.

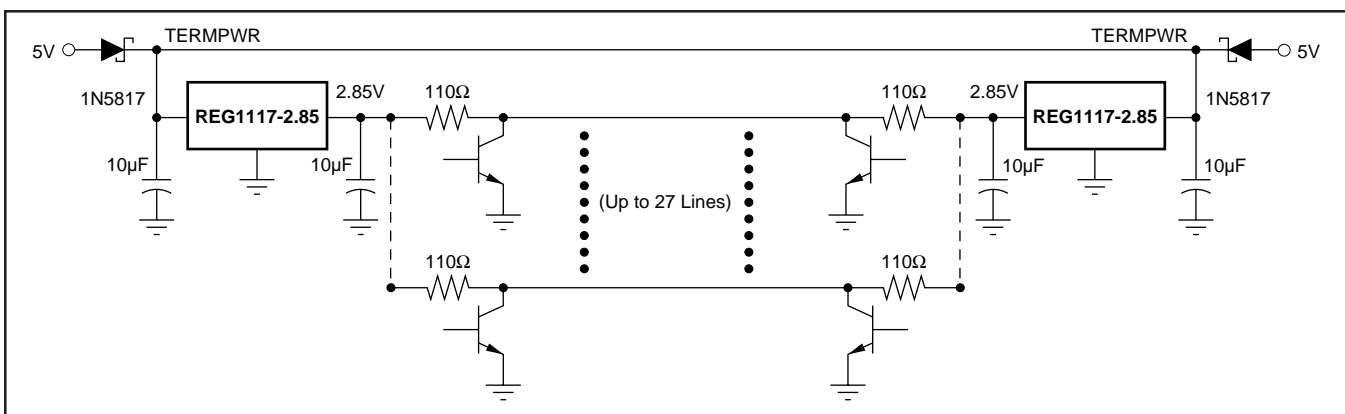

FIGURE 7. SCSI Active Termination Configuration.



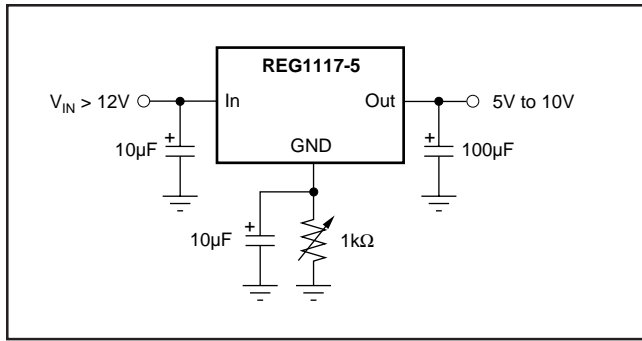

FIGURE 8. Adjusting Output of Fixed Voltage Models.

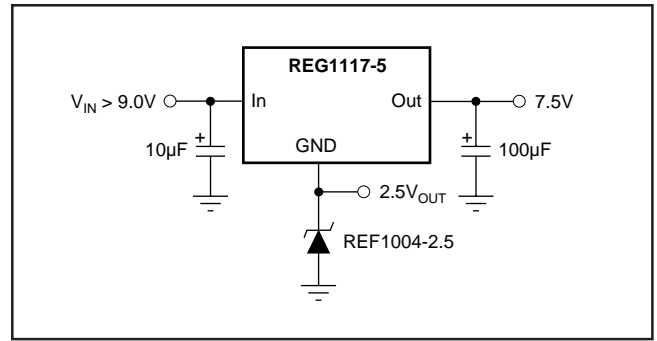

FIGURE 9. Regulator with Reference.

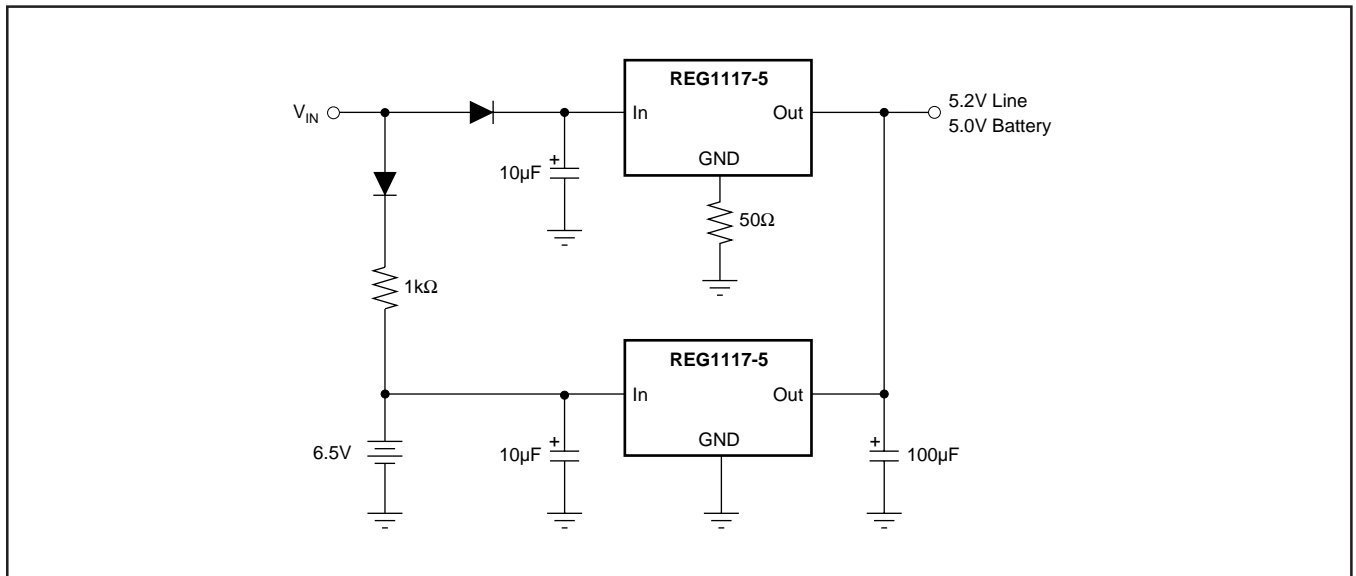

FIGURE 10. Battery Backed-Up Regulated Supply.

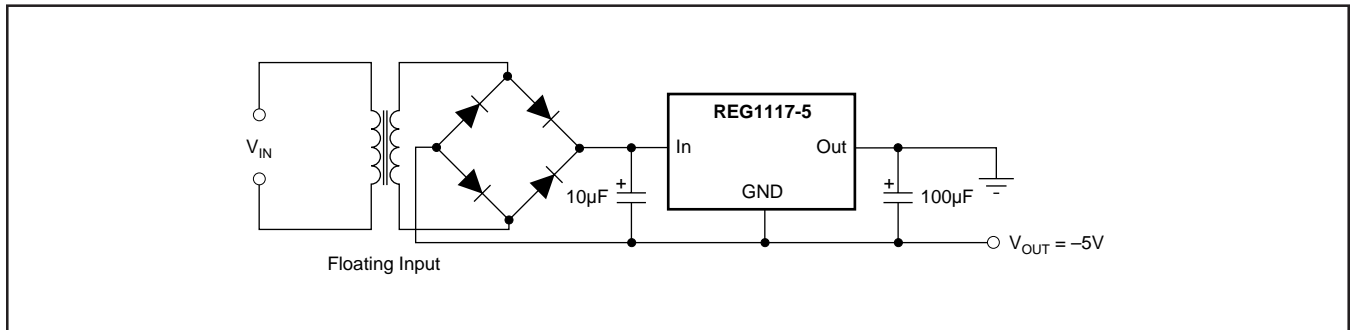

FIGURE 11. Low Dropout Negative Supply.