

# TPS2816, TPS2817, TPS2818, TPS2819, TPS2828, TPS2829 SINGLE-CHANNEL HIGH-SPEED MOSFET DRIVER

SLVS160A – FEBRUARY 1997 – REVISED NOVEMBER 1997

- Low-Cost Single-Channel High-Speed MOSFET Driver
- $I_{CC}$  . . . 15- $\mu$ A Max (TPS2828, TPS2829)
- 25-ns Max Rise/Fall Times and 40-ns Max Propagation Delay . . . 1-nF Load
- 2-A Peak Output Current
- 4-V to 14-V Driver Supply Voltage Range; Internal Regulator Extends Range to 40 V (TPS2816, TPS2817, TPS2818, TPS2819)
- 5-pin SOT-23 Package
- $-40^{\circ}\text{C}$  to  $125^{\circ}\text{C}$  Ambient-Temperature Operating Range
- Highly Resistant to Latch-ups

## description

The TPS28xx single-channel high-speed MOSFET drivers are capable of delivering peak currents of up to 2 A into highly capacitive loads. High switching speeds ( $t_r$  and  $t_f = 14$  ns typ) are obtained with the use of BiCMOS outputs. Typical threshold switching voltages are 2/3 and 1/3 of  $V_{CC}$ . The design inherently minimizes shoot-through current.

A regulator is provided on TPS2816 through TPS2819 devices to allow operation with supply inputs between 14 V and 40 V. The regulator output can be used to power other circuits, provided power dissipation does not exceed package limitations. If the regulator is not required,  $V_{DD}$  (the regulator input) should be connected to  $V_{CC}$ . The TPS2816 and TPS2817 input circuits include an active pullup circuit to eliminate the need for an external resistor when using open-collector PWM controllers. The TPS2818 and TPS2819 are identical to the TPS2816 and TPS2817, except that the active pullup circuit is omitted. The TPS2828 and TPS2829 are identical to the TPS2818 and TPS2819, except that the internal voltage regulator is omitted, allowing quiescent current to drop to less than 15  $\mu$ A when the inputs are high or low.

The TPS28xx series devices are available in 5-pin SOT-23 (DBV) packages and operate over an ambient temperature range of  $-40^{\circ}\text{C}$  to  $125^{\circ}\text{C}$ .

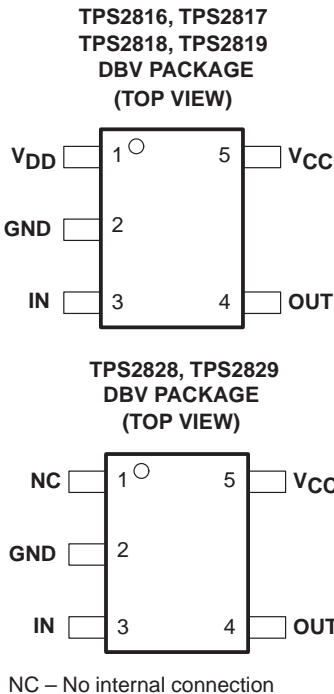

## AVAILABLE OPTIONS

T <sub>A</sub>	FUNCTION	PACKAGED DEVICES	CHIP FORM
		SOT-23-5 (DBV)	(Y)
-40°C to 125°C	Inverting driver with active pullup input	TPS2816DBV	TPS2816Y
	Noninverting driver with active pullup input	TPS2817DBV	TPS2817Y
	Inverting driver	TPS2818DBV	TPS2818Y
	Noninverting driver	TPS2819DBV	TPS2819Y
	Inverting driver, no regulator	TPS2828DBV	TPS2828Y
	Noninverting driver, no regulator	TPS2829DBV	TPS2829Y

The DBV package is available taped and reeled only.



Please be aware that an important notice concerning availability, standard warranty, and use in critical applications of Texas Instruments semiconductor products and disclaimers thereto appears at the end of this data sheet.

PRODUCTION DATA information is current as of publication date. Products conform to specifications per the terms of Texas Instruments standard warranty. Production processing does not necessarily include testing of all parameters.

 **TEXAS  
INSTRUMENTS**

POST OFFICE BOX 655303 • DALLAS, TEXAS 75265

Copyright © 1997, Texas Instruments Incorporated

# TPS2816, TPS2817, TPS2818, TPS2819, TPS2828, TPS2829 SINGLE-CHANNEL HIGH-SPEED MOSFET DRIVER

SLVS160A – FEBRUARY 1997 – REVISED NOVEMBER 1997

## functional block diagram

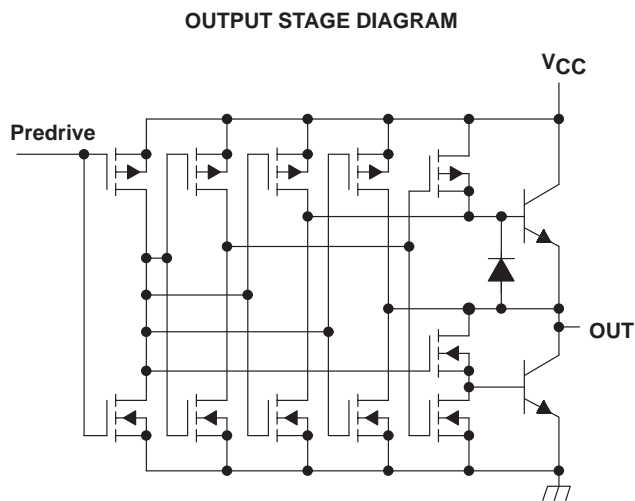
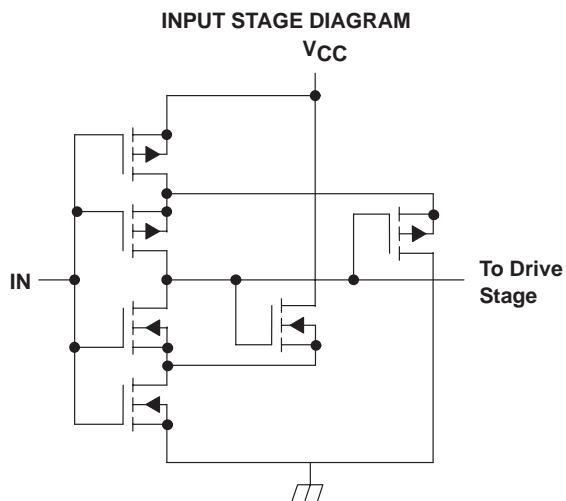
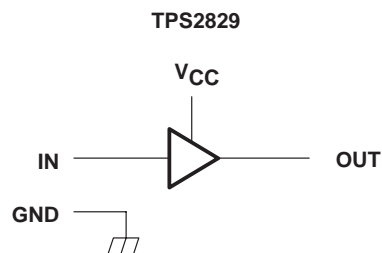
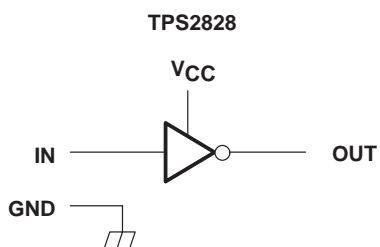
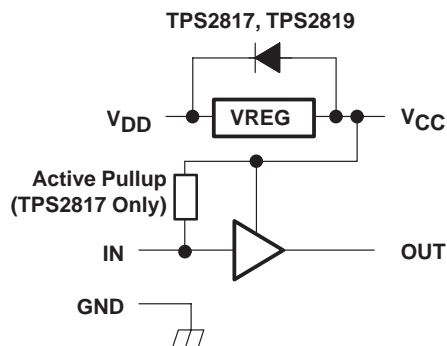
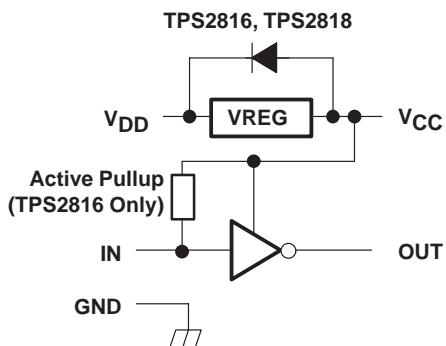

# TPS2816, TPS2817, TPS2818, TPS2819, TPS2828, TPS2829 SINGLE-CHANNEL HIGH-SPEED MOSFET DRIVER

SLVS160A – FEBRUARY 1997 – REVISED NOVEMBER 1997

## TPS28xxY chip information

This chip, when properly assembled, displays characteristics similar to those of the TPS28xx. Thermal compression or ultrasonic bonding may be used on the doped aluminum bonding pads. The chip may be mounted with conductive epoxy or a gold-silicon preform.

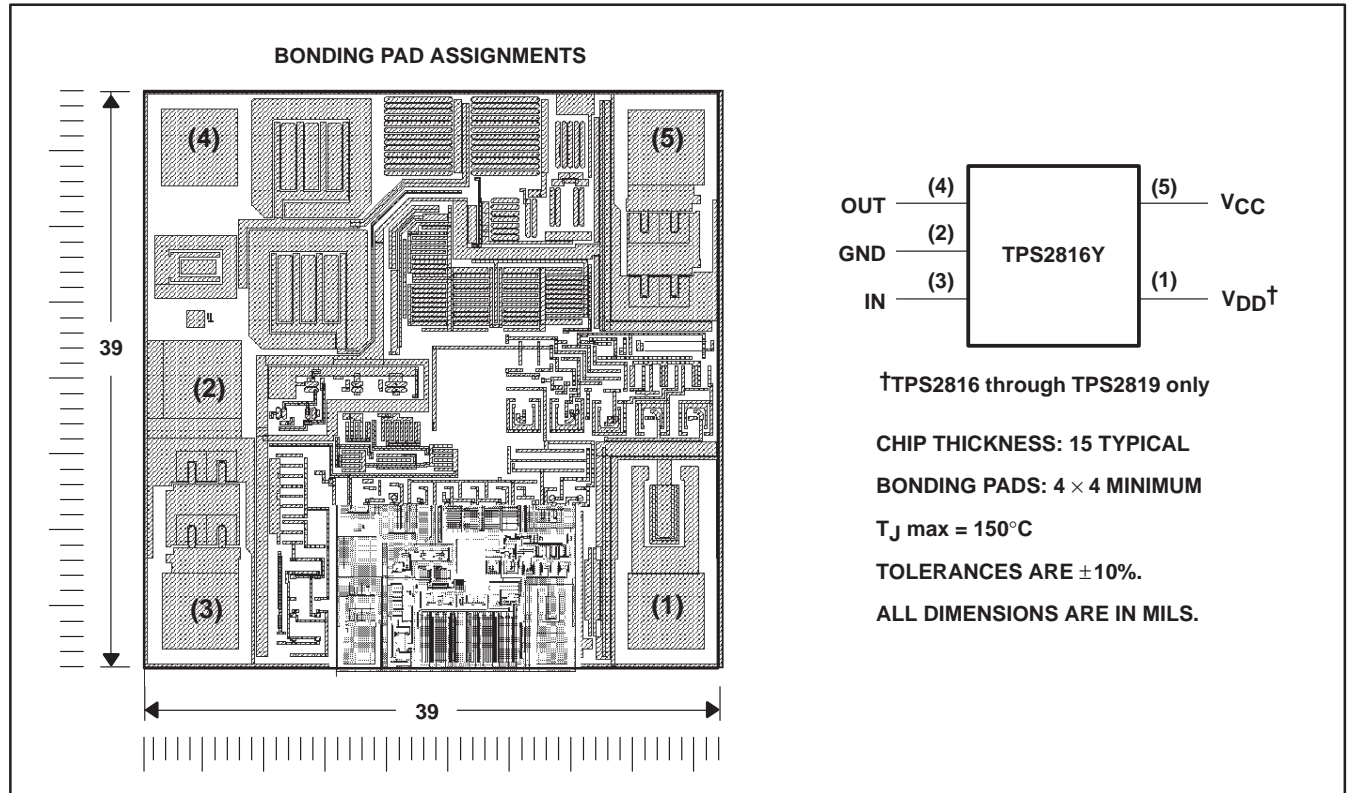

## Terminal Functions

### TPS2816, TPS2818, TPS2828 (inverting driver)

TERMINAL		DESCRIPTION
NAME	NO.	
V <sub>DD</sub>	1	Regulator supply voltage input. (Not connected on TPS2828)
GND	2	Ground
IN	3	Driver input.
OUT	4	Driver output, OUT = $\overline{\text{IN}}$
V <sub>CC</sub>	5	Driver supply voltage/regulator output voltage

### TPS2817, TPS2819, TPS2829 (noninverting driver)

TERMINAL		DESCRIPTION
NAME	NO.	
V <sub>DD</sub>	1	Regulator supply voltage input. (Not connected on TPS2829)
GND	2	Ground
IN	3	Driver input.
OUT	4	Driver output, OUT = IN
V <sub>CC</sub>	5	Driver supply voltage/regulator output voltage



# TPS2816, TPS2817, TPS2818, TPS2819, TPS2828, TPS2829 SINGLE-CHANNEL HIGH-SPEED MOSFET DRIVER

SLVS160A – FEBRUARY 1997 – REVISED NOVEMBER 1997

DISSIPATION RATING TABLE

PACKAGE	T <sub>A</sub> ≤ 25°C POWER RATING	DERATING FACTOR ABOVE T <sub>A</sub> = 25°C	T <sub>A</sub> = 70°C POWER RATING	T <sub>A</sub> = 80°C POWER RATING
DBV	437 mW	3.5 mW/°C	280 mW	227 mW

These dissipation ratings are based upon EIA specification JESD51-3, "Low Effective Thermal Conductivity Test Board for Leaded Surface Mount Packages," in tests conducted in a zero-airflow, wind tunnel environment.

## absolute maximum ratings over operating temperature range (unless otherwise noted)†

Regulator supply voltage range, V <sub>DD</sub>	–0.3 V to 42 V
Supply voltage range, V <sub>CC</sub>	–0.3 V to 15 V
Input voltage range, I <sub>N</sub>	–0.3 V to 15 V
Continuous regulator output current, V <sub>CC</sub>	25 mA
Continuous output current, O <sub>UT</sub>	±100 mA
Continuous total power dissipation	See Dissipation Rating Table
Operating ambient temperature range, T <sub>A</sub>	–40°C to 125°C
Storage temperature range, T <sub>stg</sub>	–65°C to 150°C
Lead temperature 1,6 mm (1/16inch) from case for 10 seconds	260°C

† Stresses beyond those listed under "absolute maximum ratings" may cause permanent damage to the device. These are stress ratings only, and functional operation of the device at these or any other conditions beyond those indicated under "recommended operating conditions" is not implied. Exposure to absolute-maximum-rated conditions for extended periods may affect device reliability.

NOTE 1: All voltages are with respect to device GND terminal.

## recommended operating conditions

	MIN	MAX	UNIT
Regulator input voltage range, V <sub>DD</sub> , TPS2816 through TPS2819	8	40	V
Supply voltage, V <sub>CC</sub>	4	14	V
Input voltage, I <sub>N</sub>	–0.3	V <sub>CC</sub>	V
Continuous regulator output current, I <sub>CC</sub>	0	20	mA
Operating ambient temperature range, T <sub>A</sub>	–40	125	°C



# TPS2816, TPS2817, TPS2818, TPS2819, TPS2828, TPS2829 SINGLE-CHANNEL HIGH-SPEED MOSFET DRIVER

SLVS160A – FEBRUARY 1997 – REVISED NOVEMBER 1997

**TPS28xx electrical characteristics over recommended operating ambient temperature range,  $V_{CC} = 10\text{ V}$ ,  $V_{DD}$  tied to  $V_{CC}$ ,  $C_L = 1\text{ nF}$  (unless otherwise specified)**

## Inputs

PARAMETER	TEST CONDITIONS	MIN	TYP†	MAX	UNIT
Positive-going input threshold voltage	$V_{CC} = 5\text{ V}$		3.3	4	V
	$V_{CC} = 10\text{ V}$		6.6	7	
	$V_{CC} = 14\text{ V}$		9.3	10	
Negative-going input threshold voltage	$V_{CC} = 5\text{ V}$	1	1.7		V
	$V_{CC} = 10\text{ V}$	2	3.3		
	$V_{CC} = 14\text{ V}$	2.5	4.6		
Input voltage hysteresis			1.3		V
Input current, TPS2818/19/28/29	Input = 0 V or $V_{CC}$		0.2		$\mu\text{A}$
Input current, TPS2816/17	Input = 0 V		650		$\mu\text{A}$
	Input = $V_{CC}$		15		
Input capacitance			5	10	pF

† Typical values are for  $T_A = 25^\circ\text{C}$  unless otherwise noted.

## Outputs

PARAMETER	TEST CONDITIONS	MIN	TYP†	MAX	UNIT
High-level output voltage	$I_O = -1\text{ mA}$	9.75	9.9		V
	$I_O = -100\text{ mA}$	8	9.1		
Low-level output voltage	$I_O = 1\text{ mA}$		0.18	0.25	V
	$I_O = 100\text{ mA}$		1	2	

† Typical values are for  $T_A = 25^\circ\text{C}$  unless otherwise noted.

## regulator, TPS2816 through TPS2819

PARAMETER	TEST CONDITIONS	MIN	TYP†	MAX	UNIT
Output voltage	$14 \leq V_{DD} \leq 40\text{ V}$ , $0 \leq I_O \leq 20\text{ mA}$	10	11.5	13	V
Output voltage in dropout	$I_O = 10\text{ mA}$ , $V_{DD} = 10\text{ V}$	8		10	V

† Typical values are for  $T_A = 25^\circ\text{C}$  unless otherwise noted.

## supply current

PARAMETER	TEST CONDITIONS	MIN	TYP†	MAX	UNIT
Supply current into $V_{CC}$	TPS2816, TPS2817 $I_N = \text{high} = 10\text{ V}$ $I_N = \text{low} = 0\text{ V}$		150	250	$\mu\text{A}$
			650	1000	
	TPS2818, TPS2819 $I_N = \text{high or low}$ , $\text{High} = 10\text{ V}$ , $\text{Low} = 0\text{ V}$		25	50	
Supply current into $V_{DD}$	TPS2828, TPS2829 $I_N = \text{high or low}$ , $\text{High} = 10\text{ V}$ , $\text{Low} = 0\text{ V}$		0.1	15	$\mu\text{A}$
	TPS2816, TPS2817 $V_{DD} = 20\text{ V}$ , $I_N = \text{high} = 10\text{ V}$ or $\text{low} = 0\text{ V}$		650	1000	
Supply current into $V_{DD}$	TPS2818, TPS2819 $V_{DD} = 20\text{ V}$ , $I_N = \text{high} = 10\text{ V}$ or $\text{low} = 0\text{ V}$		50	150	$\mu\text{A}$

† Typical values are for  $T_A = 25^\circ\text{C}$  unless otherwise noted.



# TPS2816, TPS2817, TPS2818, TPS2819, TPS2828, TPS2829 SINGLE-CHANNEL HIGH-SPEED MOSFET DRIVER

SLVS160A – FEBRUARY 1997 – REVISED NOVEMBER 1997

**TPS28xxY electrical characteristics at  $T_A = 25^\circ\text{C}$ ,  $V_{CC} = 10\text{ V}$ ,  $V_{DD}$  tied to  $V_{CC}$ ,  $C_L = 1\text{ nF}$  (unless otherwise specified)**

## Inputs

PARAMETER	TEST CONDITIONS	MIN	TYP	MAX	UNIT
Positive-going input threshold voltage	$V_{CC} = 5\text{ V}$		3.3		V
	$V_{CC} = 10\text{ V}$		6.6		
	$V_{CC} = 14\text{ V}$		9.3		
Negative-going input threshold voltage	$V_{CC} = 5\text{ V}$		1.7		V
	$V_{CC} = 10\text{ V}$		3.3		
	$V_{CC} = 14\text{ V}$		4.6		
Input voltage hysteresis			1.3		V
Input current, TPS2818/19/28/29	Input = 0 V or $V_{CC}$		0.2		$\mu\text{A}$
Input current, TPS2816/17	Input = 0 V		650		$\mu\text{A}$
	Input = $V_{CC}$		15		
Input resistance			1000		$\text{M}\Omega$
Input capacitance			5		pF

## outputs

PARAMETER	TEST CONDITIONS	MIN	TYP	MAX	UNIT
High-level output voltage	$I_O = -1\text{ mA}$		9.9		V
	$I_O = -100\text{ mA}$		9.1		
Low-level output voltage	$I_O = 1\text{ mA}$		0.18		V
	$I_O = 100\text{ mA}$		1		

## regulator, TPS2816 through TPS2819

PARAMETER	TEST CONDITIONS	MIN	TYP	MAX	UNIT
Output voltage	$14 \leq V_{DD} \leq 40\text{ V}$ , $0 \leq I_O \leq 20\text{ mA}$		11.5		V
Output voltage in dropout	$I_O = 10\text{ mA}$ , $V_{DD} = 10\text{ V}$		9		V

## supply current

PARAMETER	TEST CONDITIONS	MIN	TYP	MAX	UNIT
Supply current into $V_{CC}$	TPS2816, TPS2817	IN = high = 10 V		150	$\mu\text{A}$
		IN = low = 0 V		650	
	TPS2818, TPS2819	IN = high or low, High = 10 V, Low = 0 V		25	
			TPS2828, TPS2829		
Supply current into $V_{DD}$	TPS2816, TPS2817	$V_{DD} = 20\text{ V}$ , IN = high = 10 V or low = 0 V		650	$\mu\text{A}$
	TPS2818, TPS2819	$V_{DD} = 20\text{ V}$ , IN = high = 10 V or low = 0 V		50	



# TPS2816, TPS2817, TPS2818, TPS2819, TPS2828, TPS2829 SINGLE-CHANNEL HIGH-SPEED MOSFET DRIVER

SLVS160A – FEBRUARY 1997 – REVISED NOVEMBER 1997

**switching characteristics for all devices over recommended operating ambient temperature range,  $V_{CC} = 10\text{ V}$ ,  $V_{DD}$  tied to  $V_{CC}$ ,  $C_L = 1\text{ nF}$  (unless otherwise specified)**

PARAMETER		TEST CONDITIONS	MIN	TYP	MAX	UNIT
$t_r$	Rise time	$V_{CC} = 14\text{ V}$			25	ns
		$V_{CC} = 10\text{ V}$		14	30	
		$V_{CC} = 5\text{ V}$			35	
$t_f$	Fall time	$V_{CC} = 14\text{ V}$			25	ns
		$V_{CC} = 10\text{ V}$		14	30	
		$V_{CC} = 5\text{ V}$			35	
$t_{PHL}$	Propagation delay time, high-to-low-level output	$V_{CC} = 14\text{ V}$			40	ns
		$V_{CC} = 10\text{ V}$		24	45	
		$V_{CC} = 5\text{ V}$			50	
$t_{PLH}$	Propagation delay time, low-to-high-level output	$V_{CC} = 14\text{ V}$			40	ns
		$V_{CC} = 10\text{ V}$		24	45	
		$V_{CC} = 5\text{ V}$			50	

## PARAMETER MEASUREMENT INFORMATION

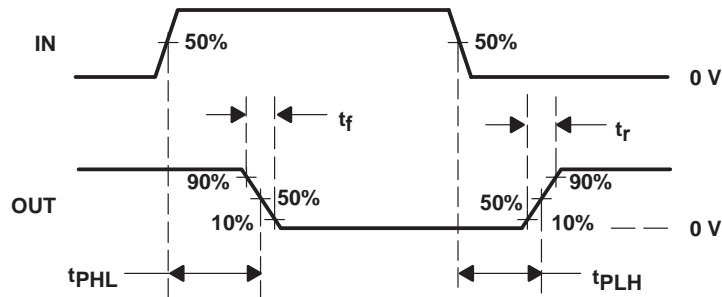

**Figure 1. Typical Timing Diagram (TPS2816)**

# TPS2816, TPS2817, TPS2818, TPS2819, TPS2828, TPS2829 SINGLE-CHANNEL HIGH-SPEED MOSFET DRIVER

SLVS160A – FEBRUARY 1997 – REVISED NOVEMBER 1997

## PARAMETER MEASUREMENT INFORMATION

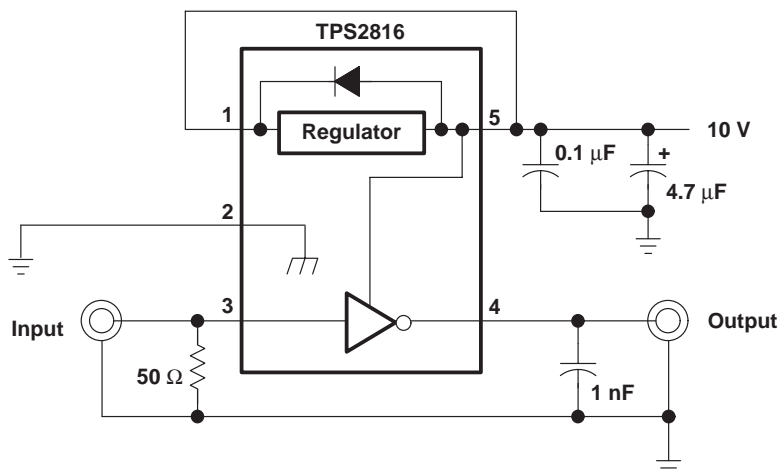

Figure 2. Switching Time Test Setup

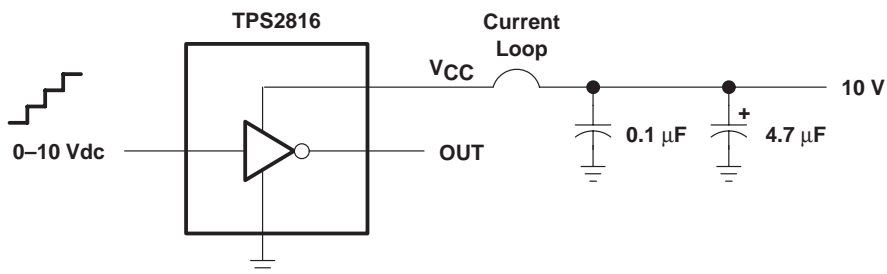

Figure 3. Shoot-Through Current Test Setup



# TPS2816, TPS2817, TPS2818, TPS2819, TPS2828, TPS2829 SINGLE-CHANNEL HIGH-SPEED MOSFET DRIVER

SLVS160A – FEBRUARY 1997 – REVISED NOVEMBER 1997

## TYPICAL CHARACTERISTICS

Table of Graphs

		FIGURE
Rise time	vs Supply voltage	4
Fall time	vs Supply voltage	5
Propagation time (L>H)	vs Supply voltage	6
Propagation Time (H>L)	vs Supply voltage	7
Rise time	vs Ambient temperature	8
Fall time	vs Ambient temperature	9
Propagation time (L>H)	vs Supply voltage	10
Propagation time (H>L)	vs Ambient temperature	11
Supply current ( $V_{CC}$ )	vs Supply voltage	12
Supply current ( $V_{CC}$ )	vs Load capacitance	13
Supply current ( $V_{CC}$ )	vs Ambient temperature	14
Input threshold voltage	vs Supply voltage	15
Regulator output voltage	vs Regulator supply voltage	16
Regulator quiescent current	vs Regulator supply voltage	17
Shoot-through current	vs Input voltage (L>H)	18
Shoot-through current	vs Input voltage (H>L)	19

TYPICAL CHARACTERISTICS

RISE TIME  
 vs  
 SUPPLY VOLTAGE

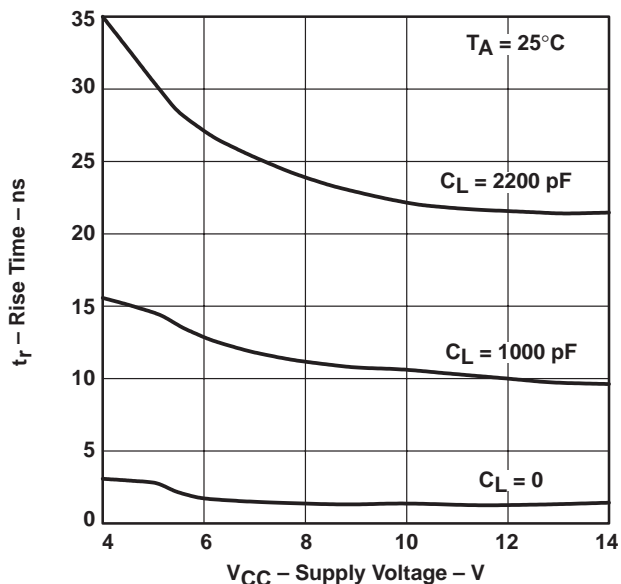

Figure 4

FALL TIME  
 vs  
 SUPPLY VOLTAGE

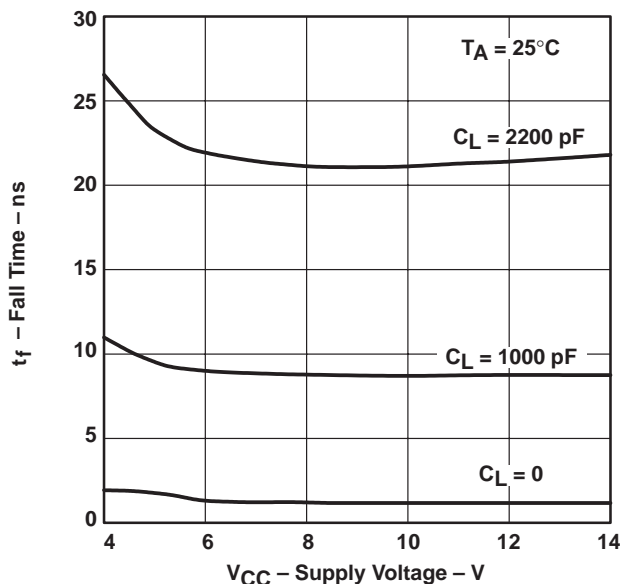

Figure 5

PROPAGATION DELAY TIME,  
 LOW-TO-HIGH-LEVEL OUTPUT  
 vs  
 SUPPLY VOLTAGE

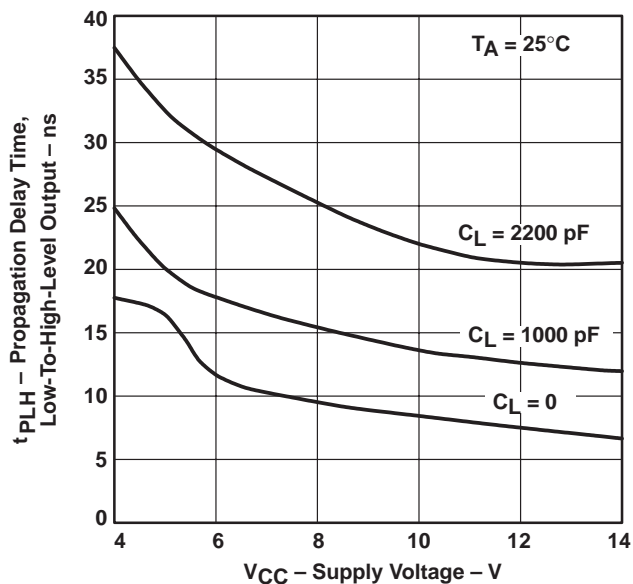

Figure 6

PROPAGATION DELAY TIME,  
 HIGH-TO-LOW-LEVEL OUTPUT  
 vs  
 SUPPLY VOLTAGE

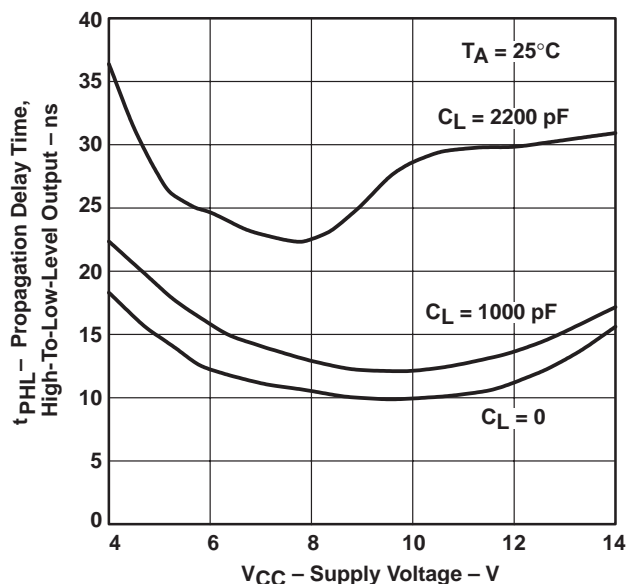

Figure 7

TYPICAL CHARACTERISTICS

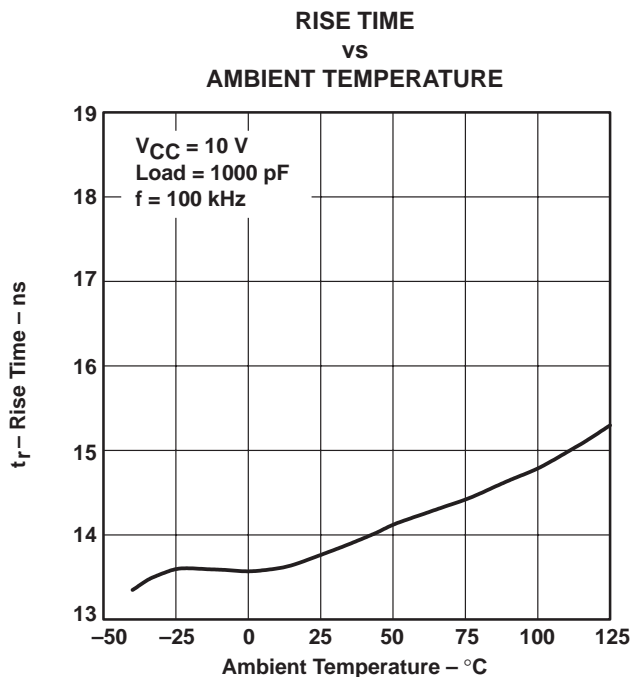

Figure 8

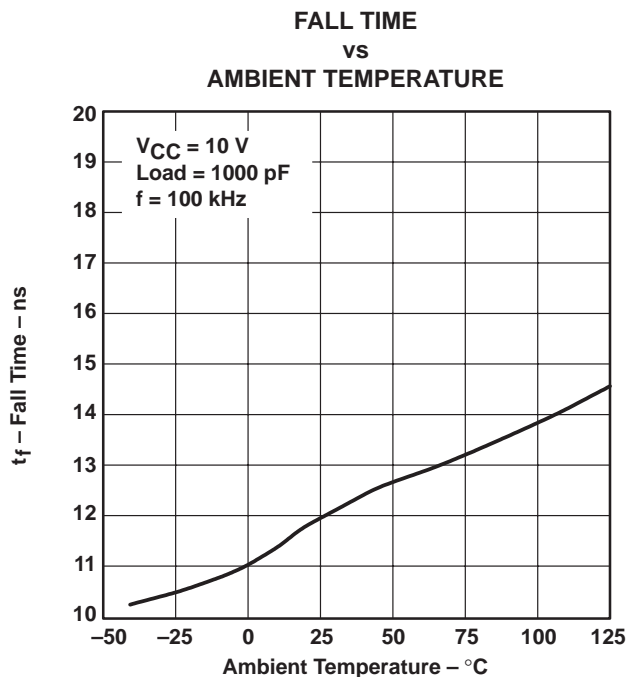

Figure 9

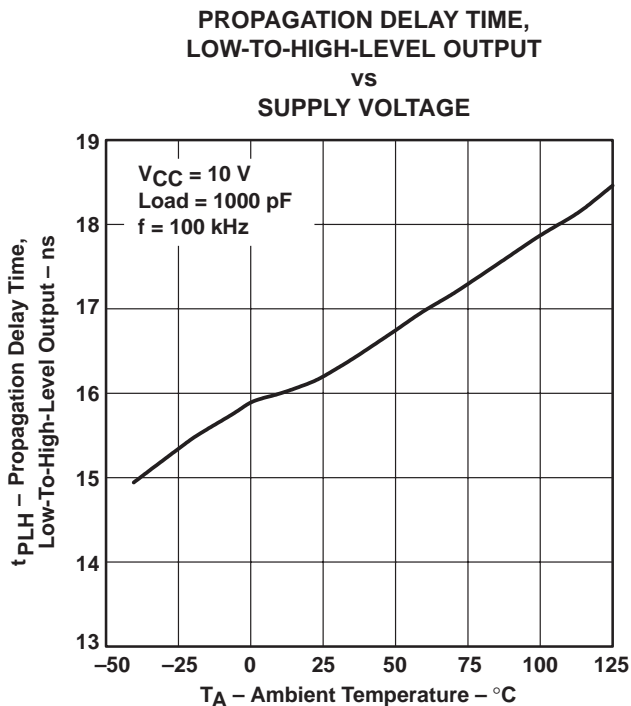

Figure 10

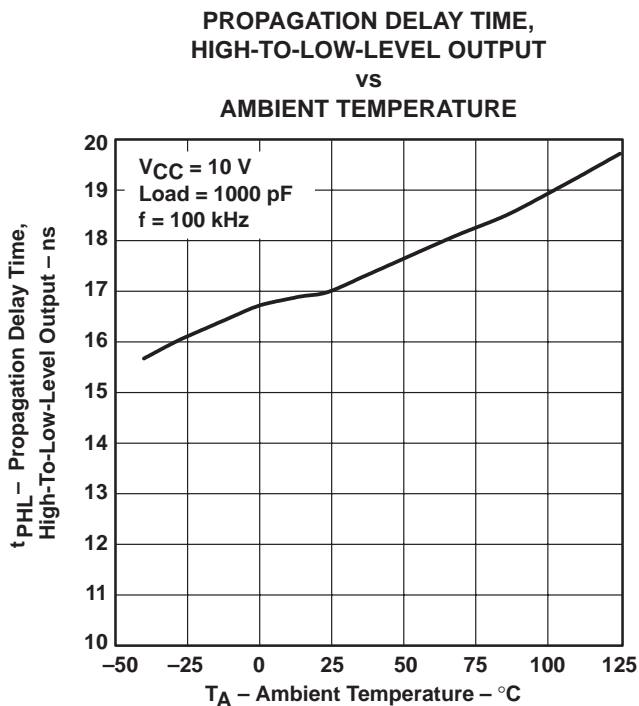

Figure 11

# TPS2816, TPS2817, TPS2818, TPS2819, TPS2828, TPS2829 SINGLE-CHANNEL HIGH-SPEED MOSFET DRIVER

SLVS160A – FEBRUARY 1997 – REVISED NOVEMBER 1997

## TYPICAL CHARACTERISTICS

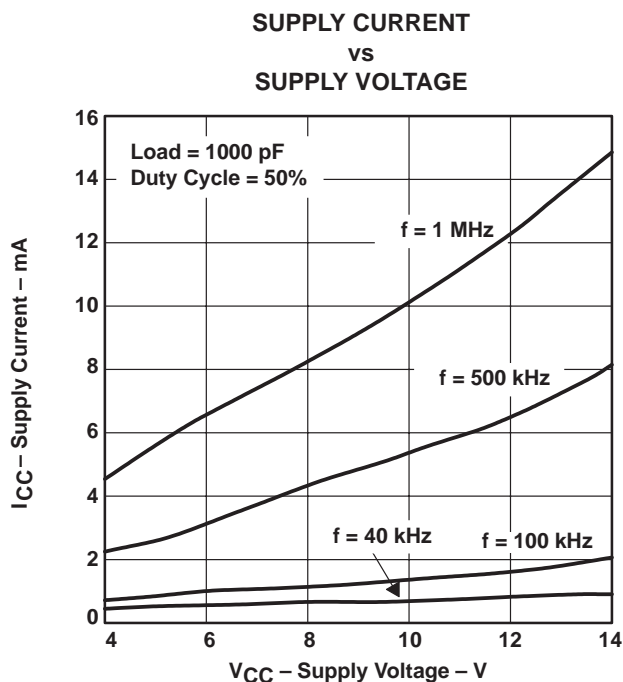

Figure 12

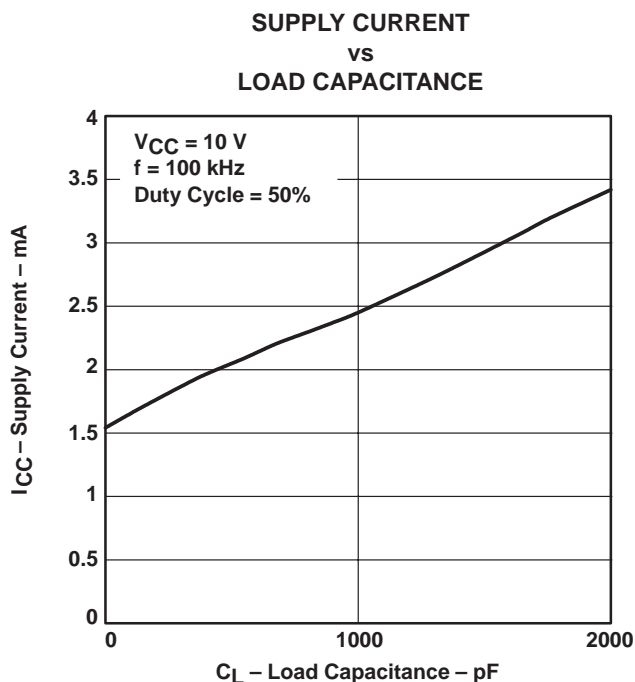

Figure 13

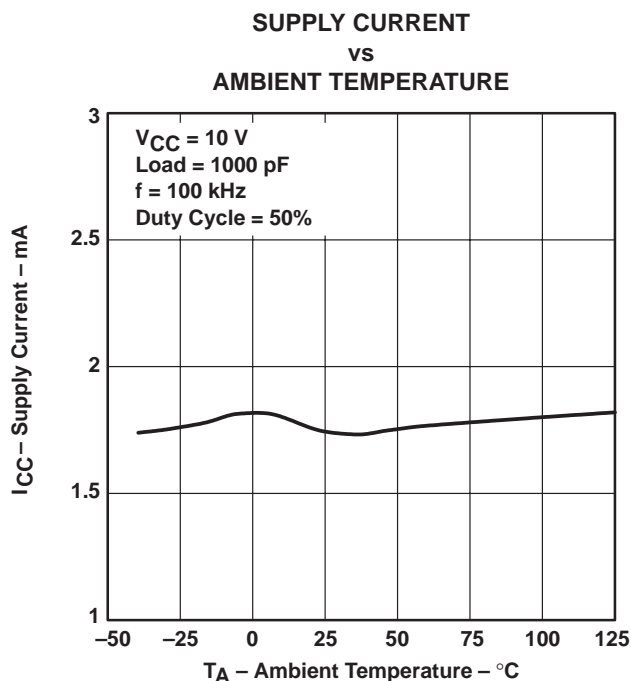

Figure 14

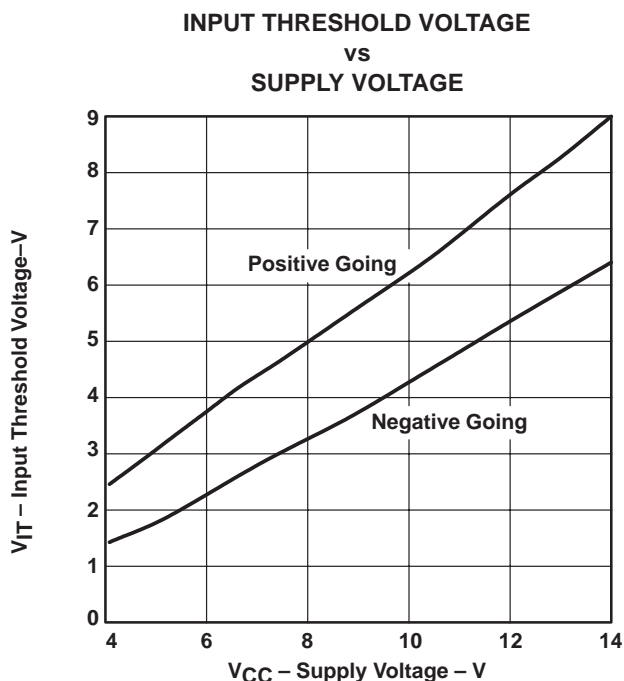

Figure 15



TYPICAL CHARACTERISTICS

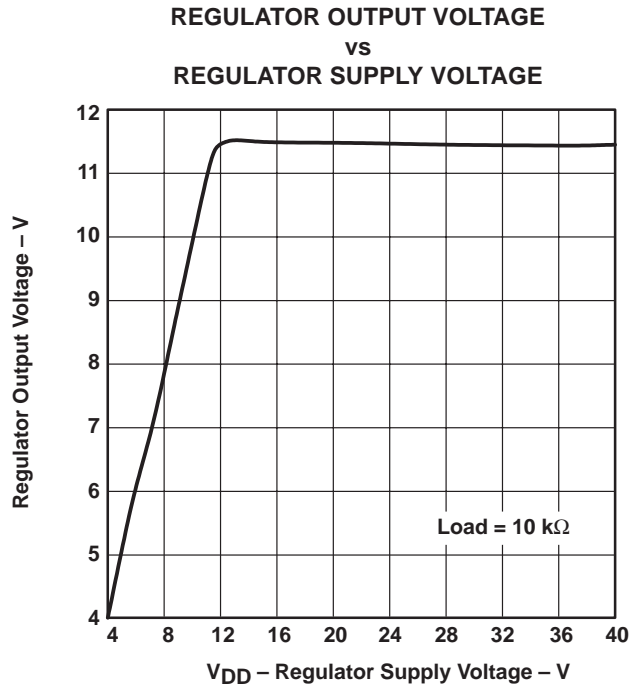

Figure 16

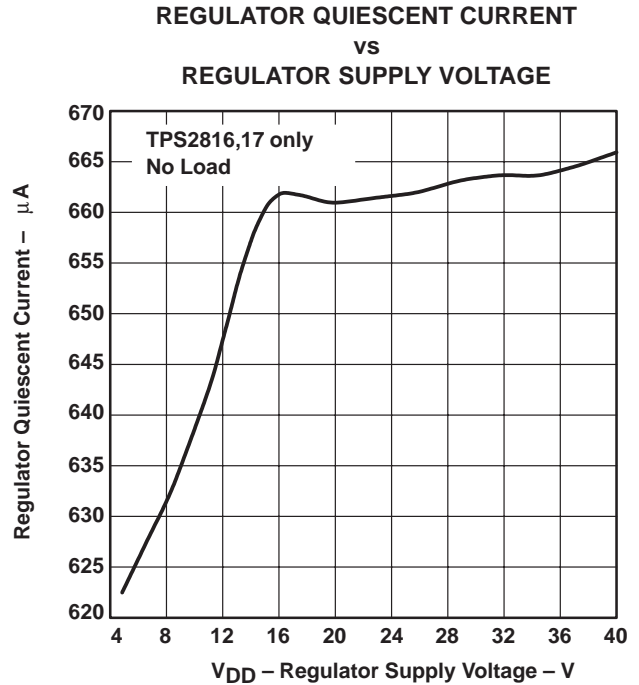

Figure 17

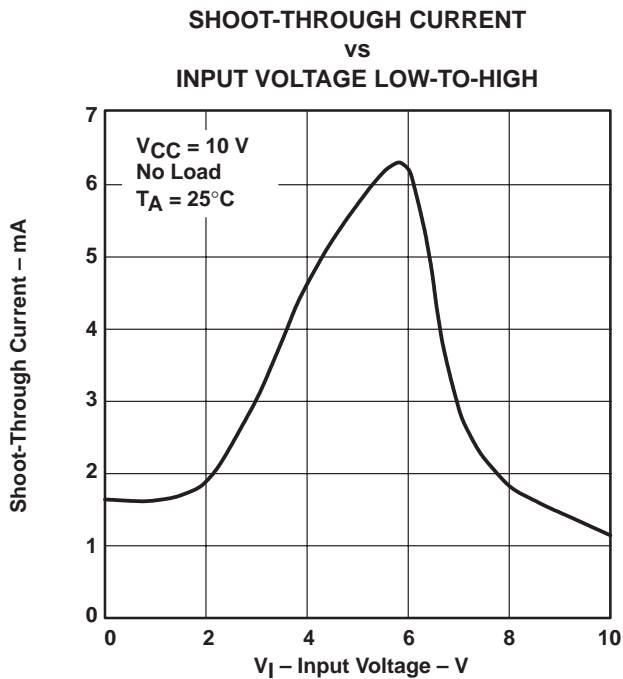

Figure 18

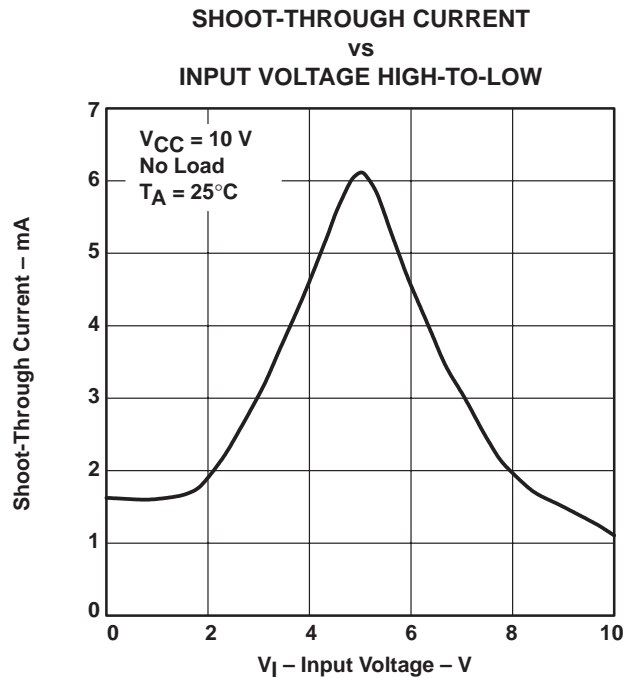

Figure 19

# TPS2816, TPS2817, TPS2818, TPS2819, TPS2828, TPS2829 SINGLE-CHANNEL HIGH-SPEED MOSFET DRIVER

SLVS160A – FEBRUARY 1997 – REVISED NOVEMBER 1997

## APPLICATION INFORMATION

MOSFETs are voltage-driven devices that require very little steady-state drive current. However, the large input capacitance (200 pF to 3000 pF or greater) of these devices requires large current surges to reduce the turn-on and turn-off times. The TPS2816 series of high-speed drivers can supply up to 2 A to a MOSFET, greatly reducing the switching times. The fast rise times and fall times and short propagation delays allow for operation in today's high-frequency switching converters.

In addition, MOSFETs have a limited gate-bias voltage range, usually less than 20 V. The TPS2816 series of drivers extends this operating range by incorporating an on-board series regulator with an input range up to 40 V. This regulator can be used to power the drivers, the PWM chip, and other circuitry, providing the power dissipation rating is not exceeded.

When using these devices, care should be exercised in the proper placement of the driver, the switching MOSFET, and the bypass capacitor. Because of the large input capacitance of the MOSFET, the driver should be placed close to the gate to eliminate the possibility of oscillations caused by trace inductance ringing with the gate capacitance of the MOSFET. When the driver output path is longer than approximately 2 inches, a resistor in the range of 10  $\Omega$  should be placed in series with the gate drive as close as possible to the MOSFET. A ceramic bypass capacitor is also recommended to provide a source for the high-speed current transients that the MOSFET requires. This capacitor should be placed between  $V_{CC}$  and GND of the driver (see Figures 20 and 21).

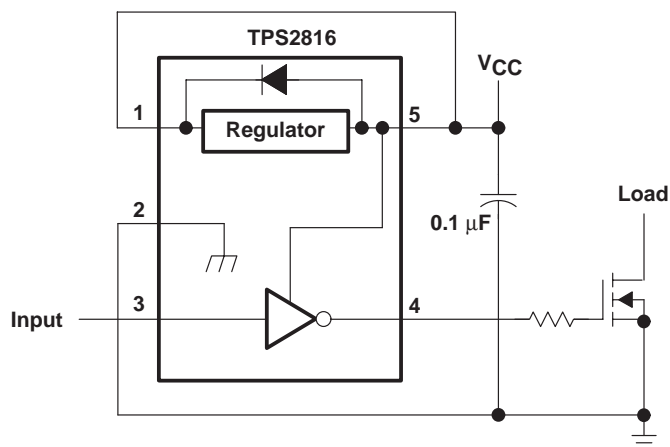

Figure 20.  $V_{CC} < 14\text{ V}$

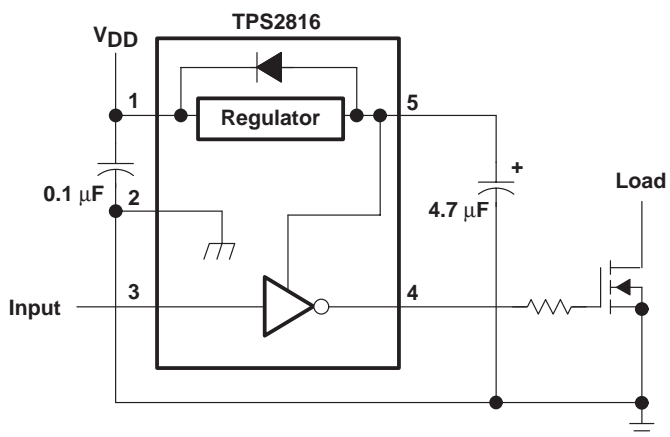

Figure 21.  $V_{CC} > 14\text{ V}$

## APPLICATION INFORMATION

The on-board series regulator supplies approximately 20 mA of current at 11.5 V, some of which can be used for external circuitry, providing the power dissipation rating for the driver is not exceeded. When using the on-board series regulator, an electrolytic output capacitor of 4.7  $\mu\text{F}$  or larger is recommended. Although not required, a 0.1- $\mu\text{F}$  ceramic capacitor on the input of the regulator can help suppress transient currents (see Figure 22). When not used, the regulator should be connected to  $V_{CC}$ . Grounding  $V_{DD}$  will result in destruction of the regulator.

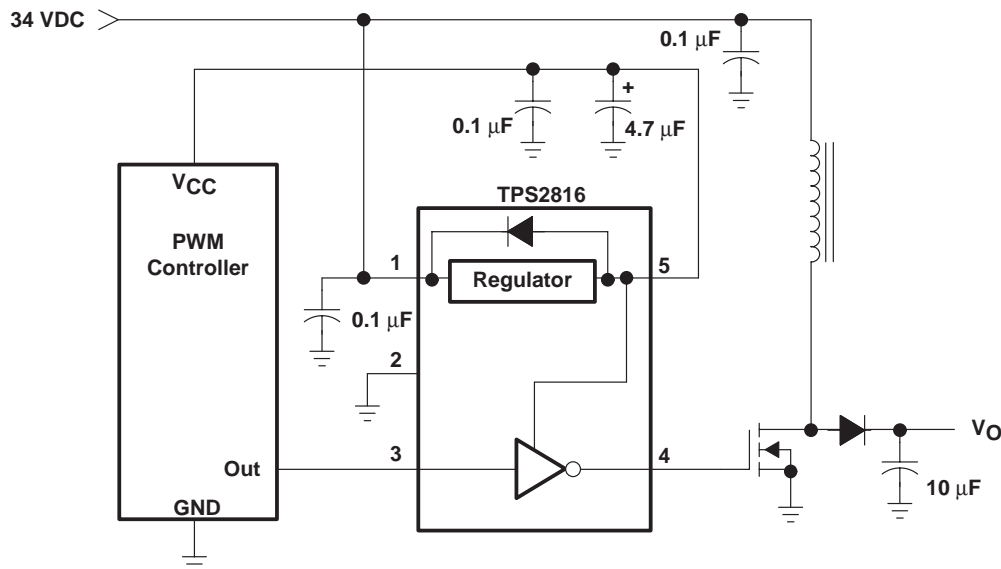

Figure 22. Boost Application

The TPS2816 and TPS2818 drivers include active pullup circuits on the inputs to eliminate the need for external pullup resistors when using controllers with open-collector outputs (such as the TL5001). The TPS2817 and TPS2819 drivers have standard CMOS inputs providing a total device operating current of less than 50  $\mu\text{A}$ . All devices switch at standard CMOS logic levels of approximately  $2/3 V_{CC}$  with positive-going input levels, and approximately  $1/3 V_{CC}$  with negative-going input levels. Being CMOS drivers, these devices will draw relatively large amounts of current (Approximately 5 mA) when the inputs are in the range of one-half of the supply voltage. In normal operation, the driver input is in this range for a very short time. Care should be taken to avoid use of very low slew-rate inputs, used under normal operating conditions. Although not destructive to the device, slew rates slower than 0.1 V/ $\mu\text{s}$  are not recommended.

The BiCMOS output stage provides high instantaneous drive current to rapidly toggle the power switch, and very low drop to each rail to ensure proper operation at voltage extremes.

Low-voltage circuits (less than 14 V) that require very low quiescent currents can use the TPS2828 and TPS2829 drivers. These drivers use typically 0.2  $\mu\text{A}$  of quiescent current (with inputs high or low). They do not have the internal regulator or the active pullup circuit, but all other specifications are the same as for the rest of the family

### 2.5-V/3.3-V, 3-A application

Figure 23 illustrates the use of the TPS2817 with a TL5001 PWM controller and a TPS1110 in a simple step-down converter application. The converter operates at 275 kHz and delivers either 2.5 V or 3.3 V (determined by the value of R6) at 3 A (5 A peak) from a 5-V supply. The bill of materials is provided in Table 1.

# TPS2816, TPS2817, TPS2818, TPS2819, TPS2828, TPS2829 SINGLE-CHANNEL HIGH-SPEED MOSFET DRIVER

SLVS160A – FEBRUARY 1997 – REVISED NOVEMBER 1997

## APPLICATION INFORMATION

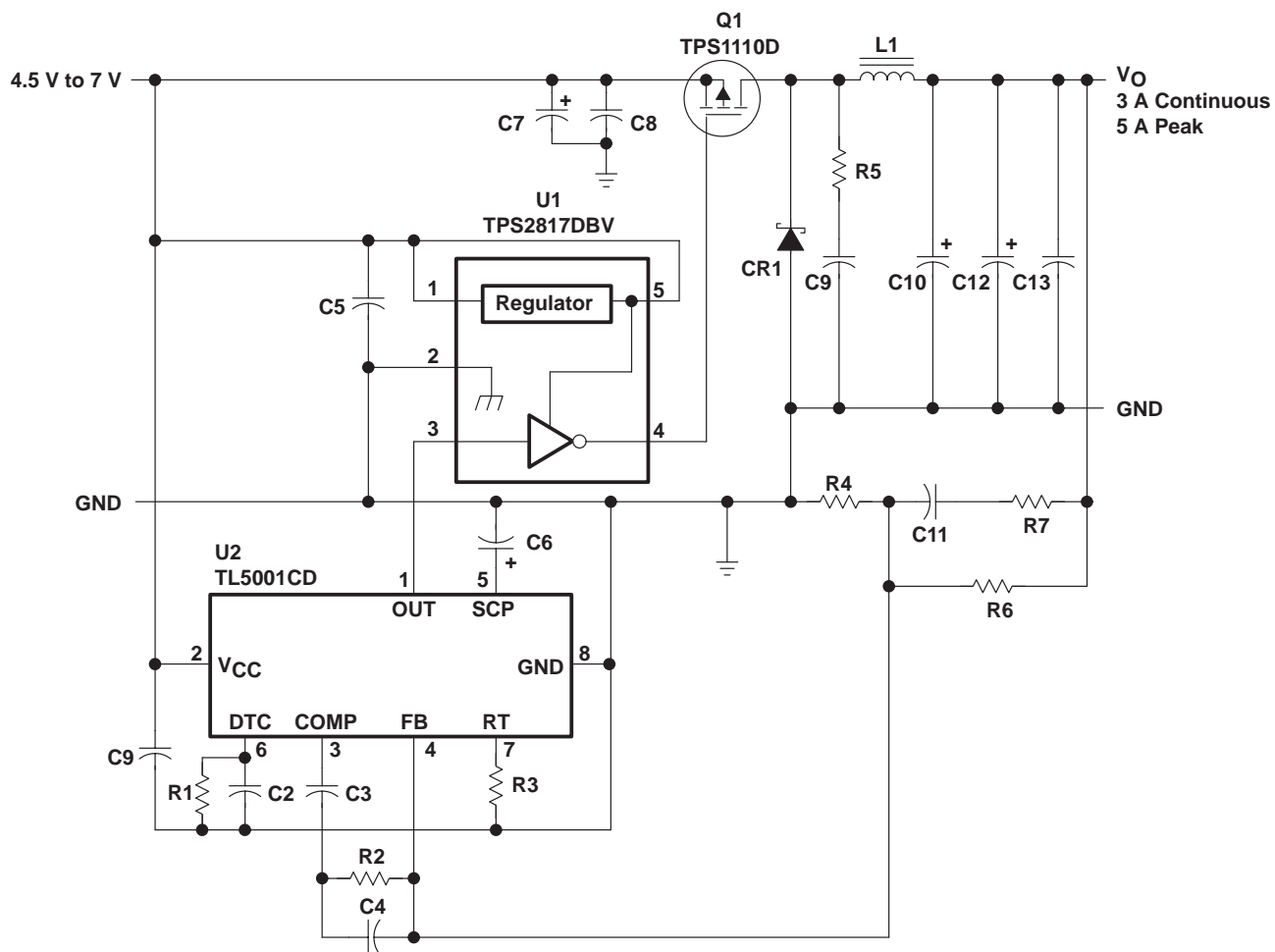

Figure 23. Step-Down Application



# TPS2816, TPS2817, TPS2818, TPS2819, TPS2828, TPS2829 SINGLE-CHANNEL HIGH-SPEED MOSFET DRIVER

SLVS160A – FEBRUARY 1997 – REVISED NOVEMBER 1997

## APPLICATION INFORMATION

**Table 1. Bill of Materials**

REF DES	PART NO.	DESCRIPTION	MFR
U1	TPS2817DBV	IC, MOSFET driver, single noninverting	TI
U2	TL5001CD	IC, PWM controller	TI
Q1	TPS1110D	MOSFET, p-channel, 6 A, 7 V, 75 m $\Omega$	TI
C1, C2, C5, C8		Capacitor, ceramic, 0.1 $\mu$ F, 50 V, X7R, 1206	
C3		Capacitor, ceramic, 0.033 $\mu$ F, 50 V, X7R, 1206	
C4		Capacitor, ceramic, 2200 pF, 50 V, X7R, 0805	
C6	ECS-T1CY105R	Capacitor, tantalum, 1.0 $\mu$ F, 16 V, A case	Panasonic
C7	10SC47M	Capacitor, OS-Con, 47 $\mu$ F, 10 V	Sanyo
C9		Capacitor, ceramic, 1000 pF, 50 V, X7R, 0805	
C10, C12	10SA220M	Capacitor, OS-Con, 220 $\mu$ F, 10 V	Sanyo
C11		Capacitor, ceramic, 0.022 $\mu$ F, 50 V, X7R, 0805	
C13		Capacitor, ceramic, 47 $\mu$ F, 50 V, X7R	
CR1	50WQ03F	Diode, Schottky, D-pak, 5 A 30 V	IR
L1	SML3723	Inductor, 27 $\mu$ H, +/- 20%, 3 A	Nova Magnetics
R1		Resistor, CF, 47 k $\Omega$ , 1/10 W, 5%, 0805	
R2		Resistor, CF, 1.5 k $\Omega$ , 1/10 W, 5%, 0805	
R3		Resistor, MF, 30.1 k $\Omega$ , 1/10 W, 1%, 0805	
R4		Resistor, MF, 1.00 k $\Omega$ , 1/10 W, 1%, 0805	
R5		Resistor, CF, 47 $\Omega$ , 1/10 W, 5%, 0805	
R6 (3.3-V)		Resistor, MF, 2.32 k $\Omega$ , 1/10 W, 1%, 0805	
R6 (2.5-V)		Resistor, MF, 1.50 k $\Omega$ , 1/10 W, 1%, 0805	
R7		Resistor, CF, 100 $\Omega$ , 1/10 W, 5%, 0805	

As shown in Figures 24 and 25, the TPS2817 turns on the TPS1110 power switch in less than 20 ns and off in 25 ns.

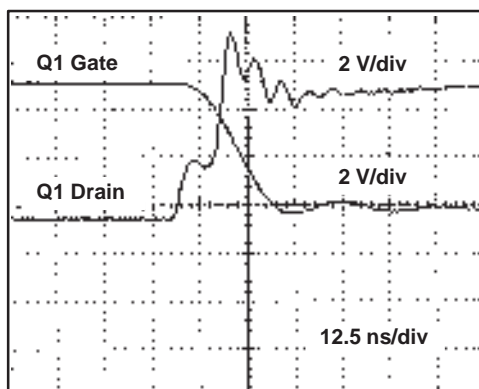

**Figure 24. Q1 Turn-On Waveform**

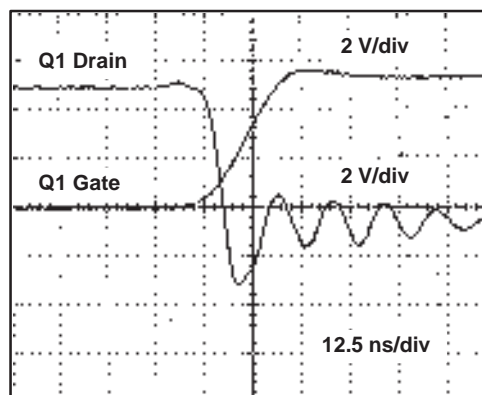

**Figure 25. Q1 Turn-Off Waveform**

# TPS2816, TPS2817, TPS2818, TPS2819, TPS2828, TPS2829 SINGLE-CHANNEL HIGH-SPEED MOSFET DRIVER

SLVS160A – FEBRUARY 1997 – REVISED NOVEMBER 1997

## APPLICATION INFORMATION

The efficiency for various output currents, with a 5.25-V input, is shown in Figure 26. For a 3.3-V output, the efficiency is greater than 90% for loads up to 2 A – exceptional for a simple, inexpensive design.

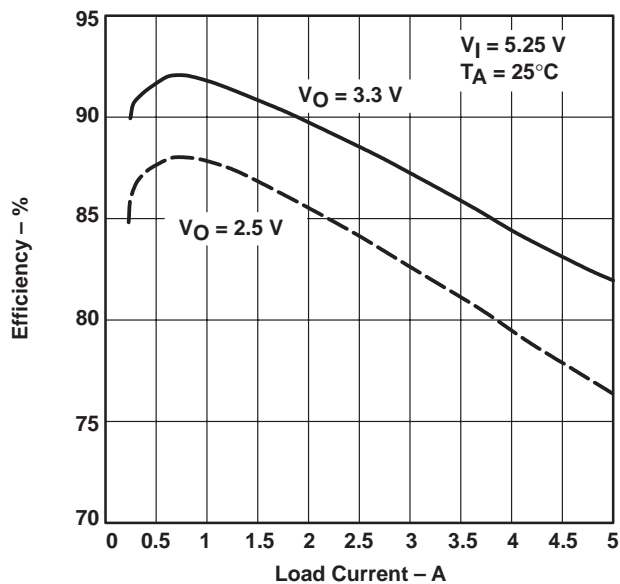

Figure 26. Converter Efficiency

TPS2816, TPS2817, TPS2818, TPS2819, TPS2828, TPS2829  
SINGLE-CHANNEL HIGH-SPEED MOSFET DRIVER

SLVS160A – FEBRUARY 1997 – REVISED NOVEMBER 1997

MECHANICAL DATA

DBV (R-PDSO-G5)

PLASTIC SMALL-OUTLINE PACKAGE

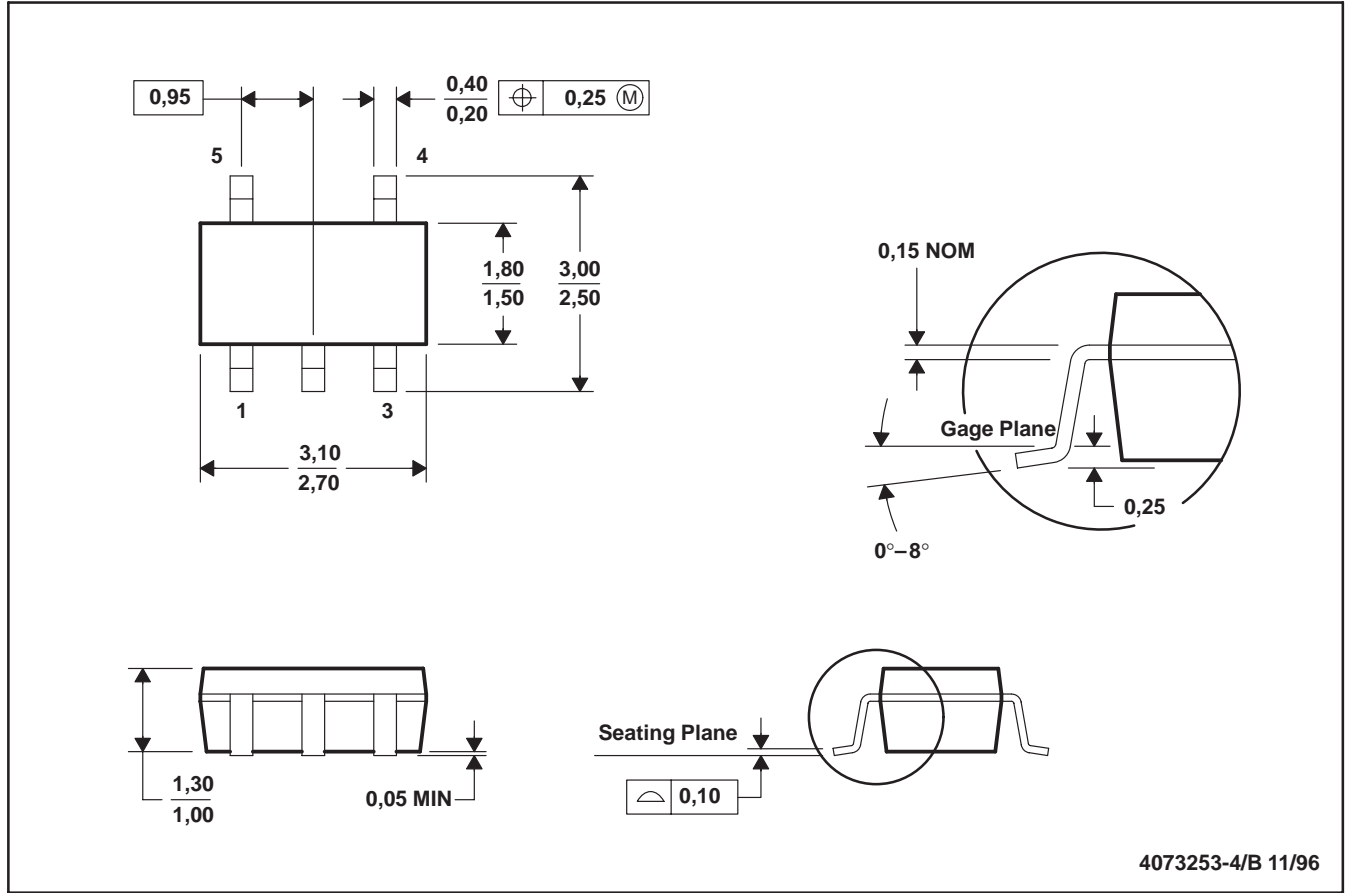

- NOTES: A. All linear dimensions are in millimeters.  
B. This drawing is subject to change without notice.  
C. Body dimensions include mold flash or protrusion.

## IMPORTANT NOTICE

Texas Instruments and its subsidiaries (TI) reserve the right to make changes to their products or to discontinue any product or service without notice, and advise customers to obtain the latest version of relevant information to verify, before placing orders, that information being relied on is current and complete. All products are sold subject to the terms and conditions of sale supplied at the time of order acknowledgement, including those pertaining to warranty, patent infringement, and limitation of liability.

TI warrants performance of its semiconductor products to the specifications applicable at the time of sale in accordance with TI's standard warranty. Testing and other quality control techniques are utilized to the extent TI deems necessary to support this warranty. Specific testing of all parameters of each device is not necessarily performed, except those mandated by government requirements.

CERTAIN APPLICATIONS USING SEMICONDUCTOR PRODUCTS MAY INVOLVE POTENTIAL RISKS OF DEATH, PERSONAL INJURY, OR SEVERE PROPERTY OR ENVIRONMENTAL DAMAGE ("CRITICAL APPLICATIONS"). TI SEMICONDUCTOR PRODUCTS ARE NOT DESIGNED, AUTHORIZED, OR WARRANTED TO BE SUITABLE FOR USE IN LIFE-SUPPORT DEVICES OR SYSTEMS OR OTHER CRITICAL APPLICATIONS. INCLUSION OF TI PRODUCTS IN SUCH APPLICATIONS IS UNDERSTOOD TO BE FULLY AT THE CUSTOMER'S RISK.

In order to minimize risks associated with the customer's applications, adequate design and operating safeguards must be provided by the customer to minimize inherent or procedural hazards.

TI assumes no liability for applications assistance or customer product design. TI does not warrant or represent that any license, either express or implied, is granted under any patent right, copyright, mask work right, or other intellectual property right of TI covering or relating to any combination, machine, or process in which such semiconductor products or services might be or are used. TI's publication of information regarding any third party's products or services does not constitute TI's approval, warranty or endorsement thereof.