



DUAL PROCESSOR SUPERVISORS

FEATURES

- Dual Supervisory Circuits for DSP- and Processor-Based Systems
- Power-On Reset Generator with Fixed Delay Time of 200ms; no External Capacitor Needed
- Watchdog Timer Retriggeres the $\overline{\text{RESET}}$ Output at $\text{SENSEn} \geq V_{IT+}$
- Temperature-Compensated Voltage Reference
- Maximum Supply Current of 40 μA
- Supply Voltage Range: 2.7V to 6V
- Defined $\overline{\text{RESET}}$ Output From $V_{DD} \geq 1.1\text{V}$
- MSOP-8 and SO-8 Packages
- Temperature Range: -40°C to $+85^{\circ}\text{C}$

APPLICATIONS

- Processor Supply Monitoring
- Industrial Equipment
- Automotive Systems
- Portable/Battery-Powered Equipment
- Wireless Communication Systems
- Notebook/Desktop Computers

DESCRIPTION

The TPS3305 family is a series of micropower supply voltage supervisors designed for circuit initialization. Its dual monitor topology is well-suited to use in DSP and processor-based systems, which often require two supply voltages, core and I/O.

$\overline{\text{RESET}}$ is asserted when the voltage at either SENSEn pin falls below its threshold voltage, V_{IT} . When both SENSEn pins are again above their respective threshold voltages, $\overline{\text{RESET}}$ is held low for the factory-programmed delay time (200ms typ). $\overline{\text{RESET}}$ is also asserted if the watchdog input (WDI) is not toggled for more than 1.6s typ.

The TPS3305-xx devices are available in either 8-pin MSOP or SO packages, and are specified for operation over a temperature range of -40°C to $+85^{\circ}\text{C}$.

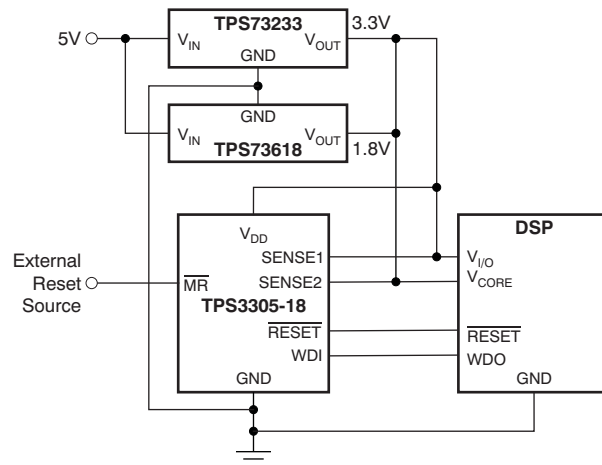
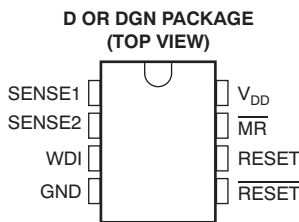

Please be aware that an important notice concerning availability, standard warranty, and use in critical applications of Texas Instruments semiconductor products and disclaimers thereto appears at the end of this data sheet.

All trademarks are the property of their respective owners.



This integrated circuit can be damaged by ESD. Texas Instruments recommends that all integrated circuits be handled with appropriate precautions. Failure to observe proper handling and installation procedures can cause damage.

ESD damage can range from subtle performance degradation to complete device failure. Precision integrated circuits may be more susceptible to damage because very small parametric changes could cause the device not to meet its published specifications.

ORDERING INFORMATION⁽¹⁾

DEVICE	NOMINAL SUPERVISED VOLTAGE		THRESHOLD VOLTAGE (TYP)	
	SENSE1	SENSE2	SENSE1	SENSE2
TPS3305-18	3.3 V	1.8 V	2.93 V	1.68 V
TPS3305-25	3.3 V	2.5 V	2.93 V	2.25 V
TPS3305-33	5.0 V	3.3 V	4.55 V	2.93 V

(1) For the most current specifications and package information, see the Package Option Addendum at the end of this document, or see the TI website at www.ti.com.

ABSOLUTE MAXIMUM RATINGS⁽¹⁾⁽²⁾

Over operating junction temperature range (unless otherwise noted).

	UNIT
Supply voltage range, V_{DD}	-0.3V to +7V
V_{MR} , V_{WDI}	-0.3V to $V_{DD} + 0.3V$
Input voltage at SENSE1 and SENSE2, V_I	$(V_{DD} + 0.3)V_{IT} / 1.25V$
V_{RESET} , $V_{\overline{RESET}}$	-0.3V to +7V
Maximum low output current, I_{OL}	5mA
Maximum high output current, I_{OH}	-5mA
Input clamp current, I_{IK} ($V_I < 0$ or $V_I > V_{DD}$)	$\pm 20mA$
Output clamp current, I_{OK} ($V_O < 0$ or $V_O > V_{DD}$)	$\pm 20mA$
Continuous total power dissipation	See Dissipation Ratings Table
Operating junction temperature range, T_J	-40°C to +85°C
Storage temperature range, T_{stg}	-65°C to +150°C
Soldering temperature	+260°C

(1) Stresses beyond those listed under *absolute maximum ratings* may cause permanent damage to the device. These are stress ratings only, and functional operation of the device at these or any other conditions beyond those indicated under *recommended operating conditions* is not implied. Exposure to absolute-maximum-rated conditions for extended periods may affect device reliability.

(2) All voltage values are with respect to GND.

DISSIPATION RATINGS TABLE

PACKAGE	$T_A \leq +25^\circ C$ POWER RATING	DERATING FACTOR ABOVE $T_A = +25^\circ C$	$T_A = +70^\circ C$ POWER RATING	$T_A = +85^\circ C$ POWER RATING
DGN	2.14W	17.1mW/°C	1.37W	1.11W
D	725mW	5.8mW/°C	464mW	377mW

ELECTRICAL CHARACTERISTICS

Over operating junction temperature range (unless otherwise noted).

PARAMETER		TEST CONDITIONS	TPS3305-xx			UNIT	
			MIN	TYP	MAX		
V _{DD}	Input supply range		2.7		6.0	V	
T _J	Operating junction temperature range		-40		+85	°C	
V _{OH}	High-level output voltage	V _{DD} = 2.7V to 6V, I _{OH} = -20μA	V _{DD} - 0.2V			V	
		V _{DD} = 3.3V, I _{OH} = -2mA	V _{DD} - 0.4V			V	
		V _{DD} = 6V, I _{OH} = -3mA	V _{DD} - 0.4V			V	
V _{OL}	Low-level output voltage	V _{DD} = 2.7V to 6V, I _{OL} = 20μA				0.2	V
		V _{DD} = 3.3V, I _{OL} = 2mA				0.4	V
		V _{DD} = 6V, I _{OL} = 3mA				0.4	V
Power-up reset voltage ⁽¹⁾		V _{DD} ≥ 1.1V, I _{OL} = 20μA				0.4	V
V _{IT-}	Negative-going input threshold voltage ⁽²⁾	V _{DD} = 2.7V to 6V, T _A = 0°C to +85°C	VSENSE1, VSENSE2	1.64	1.68	1.72	V
				2.20	2.25	2.30	V
				2.86	2.93	3.0	V
				4.46	4.55	4.64	V
		V _{DD} = 2.7V to 6V, T _A = -40°C to +85°C	VSENSE1, VSENSE2	1.64	1.68	1.73	V
				2.20	2.25	2.32	V
				2.86	2.93	3.02	V
				4.46	4.55	4.67	V
V _{hys}	Hysteresis at VSENSEn input	V _{IT-} = 1.68V		15	mV		
		V _{IT-} = 2.25V		20	mV		
		V _{IT-} = 2.93V		30	mV		
		V _{IT-} = 4.55V		40	mV		
I _{H(AV)}	Average high-level input current	WDI	WDI = V _{DD} = 6V Time average (dc = 88%)		100	150	μA
I _{L(AV)}	Average low-level input current	WDI	WDI = 0V, V _{DD} = 6V Time average (dc = 12%)		-15	-20	μA
V _{IH}	High-level input voltage at \overline{MR} and WDI			0.7 x V _{DD}		V	
V _{IL}	Low-level input voltage at \overline{MR} and WDI			0.3 x V _{DD}		V	
Δt / ΔV	Input transition rise and fall rate at \overline{MR}			50		ns/V	
I _H	High-level input current	WDI	WDI = V _{DD} = 6V		120	170	μA
		\overline{MR}	$\overline{MR} = 0.7 \times V_{DD}$, V _{DD} = 6V		-130	-180	μA
		SENSE1	VSENSE1 = V _{DD} = 6V		5	8	μA
		SENSE2	VSENSE2 = V _{DD} = 6V		6	9	μA
I _L	Low-level input current	WDI	WDI = 0V, V _{DD} = 6V		-120	-170	μA
		\overline{MR}	$\overline{MR} = 0V$, V _{DD} = 6V		-430	-600	μA
		SENSEn	VSENSE1,2 = 0V		-1	1	μA
I _{DD}	Supply current			40		μA	
C _I	Input capacitance	V _I = 0V to V _{DD}		10	pF		

(1) The lowest supply voltage at which **RESET** becomes active. t_r, V_{DD} ≥ 15 μs/V.

(2) To ensure best stability of the threshold voltage, a bypass capacitor (0.1 μF ceramic) should be placed close to the supply terminals.

TIMING DIAGRAM

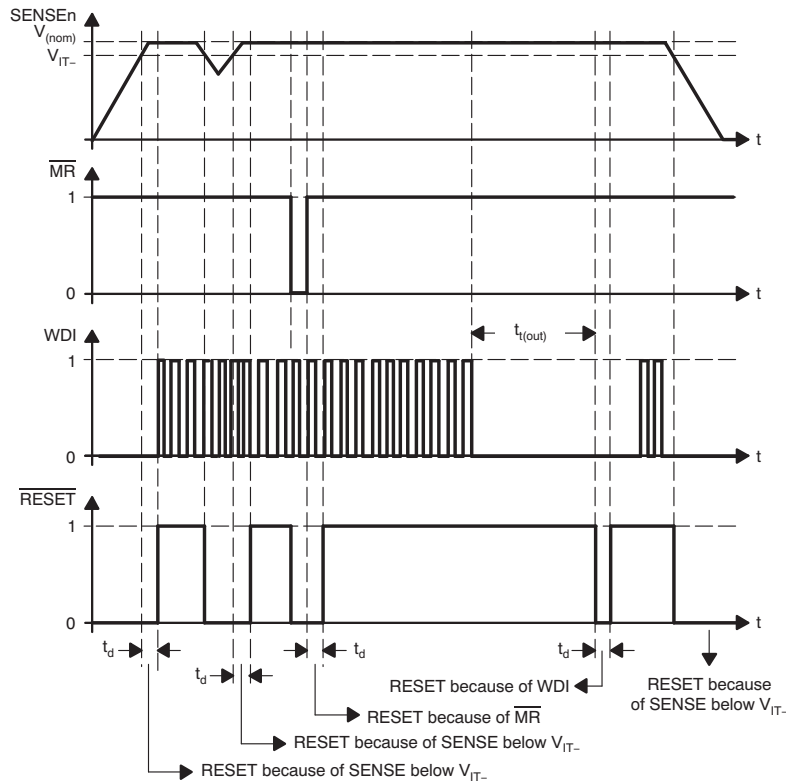

TIMING REQUIREMENTS

At $V_{DD} = 2.7V$ to $6V$, $R_L = 1M\Omega$, $C_L = 50pF$, and $T_J = +25^\circ C$.

PARAMETER		TEST CONDITIONS	MIN	TYP	MAX	UNIT
t_w	Pulse width	$V_{SENSEnL} = V_{IT-} - 0.2V$, $V_{SENSEnH} = V_{IT+} + 0.2V$	6			μs
		$V_{IH} = 0.7 \times V_{DD}$, $V_{IL} = 0.3 \times V_{DD}$	100			ns
			100			ns

SWITCHING CHARACTERISTICS

At $V_{DD} = 2.7V$ to $6V$, $R_L = 1M\Omega$, $C_L = 50pF$, and $T_J = +25^\circ C$.

PARAMETER		TEST CONDITIONS	MIN	TYP	MAX	UNIT
$t_{t(out)}$	Watchdog time-out	$V_{I(SENSEn)} \geq V_{IT+} + 0.2V$, $\overline{MR} \geq 0.7 \times V_{DD}$ See Timing Diagram	1.1	1.6	2.3	s
t_d	Delay time	$V_{I(SENSEn)} \geq V_{IT+} + 0.2V$, $\overline{MR} \geq 0.7 \times V_{DD}$ See Timing Diagram	140	200	280	ms
t_{PHL}	Propagation (delay) time, high-to-low level output	\overline{MR} to \overline{RESET} , \overline{MR} to RESET $V_{I(SENSEn)} \geq V_{IT+} + 0.2V$, $V_{IH} = 0.7 \times V_{DD}$, $V_{IL} = 0.3 \times V_{DD}$		200	500	ns
t_{PLH}	Propagation (delay) time, low-to-high level output	\overline{MR} to \overline{RESET} , \overline{MR} to RESET $V_{I(SENSEn)} \geq V_{IT+} + 0.2V$, $V_{IH} = 0.7 \times V_{DD}$, $V_{IL} = 0.3 \times V_{DD}$		200	500	ns
t_{PHL}	Propagation (delay) time, high-to-low level output	$SENSEn$ to \overline{RESET} , $SENSEn$ to RESET $V_{IH} = V_{IT+} + 0.2V$, $V_{IL} = V_{IT-} - 0.2V$, $\overline{MR} \geq 0.7 \times V_{DD}$		1	5	μs
t_{PLH}	Propagation (delay) time, low-to-high level output	$SENSEn$ to \overline{RESET} , $SENSEn$ to RESET $V_{IH} = V_{IT+} + 0.2V$, $V_{IL} = V_{IT-} - 0.2V$, $\overline{MR} \geq 0.7 \times V_{DD}$		1	5	μs

DEVICE INFORMATION

FUNCTION/TRUTH TABLE⁽¹⁾

MR	SENSE1 > V _{IT1}	SENSE2 > V _{IT2}	RESET	RESET
L	X	X	L	H
H	0	0	L	H
H	0	1	L	H
H	1	0	L	H
H	1	1	H	L

(1) X = Don't care

FUNCTIONAL BLOCK DIAGRAM

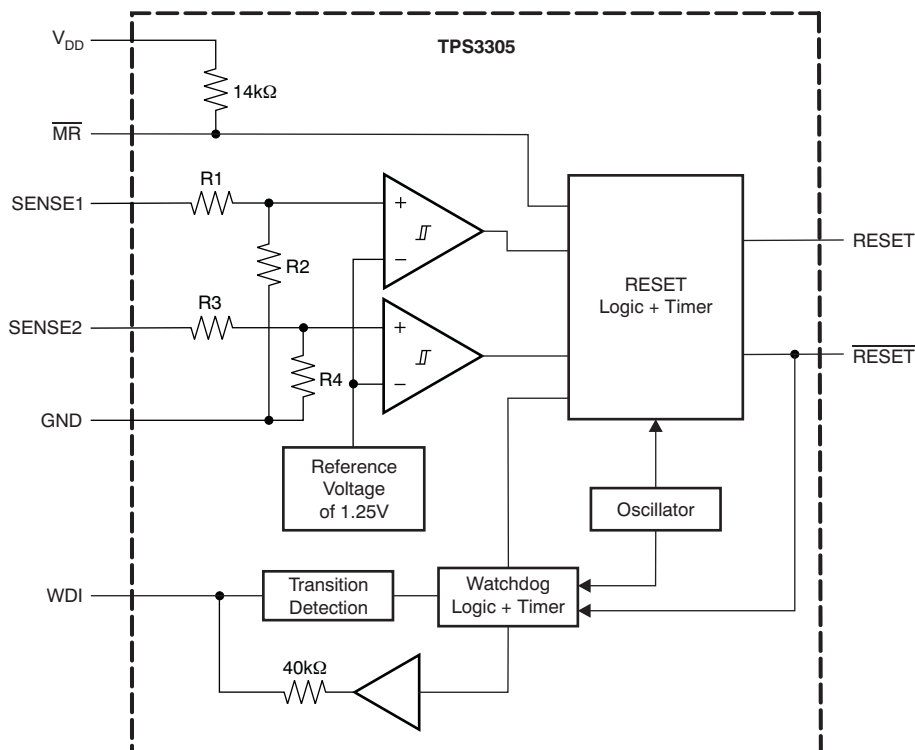

TERMINAL FUNCTIONS

TERMINAL		DESCRIPTION
NAME	NO.	
GND	4	Ground
MR	7	Manual reset
RESET	5	Active-low reset output
RESET	6	Active-high reset output
SENSE1	1	Sense voltage input 1
SENSE2	2	Sense voltage input 2
WDI	3	Watchdog timer input
V _{DD}	8	Supply voltage

TYPICAL CHARACTERISTICS

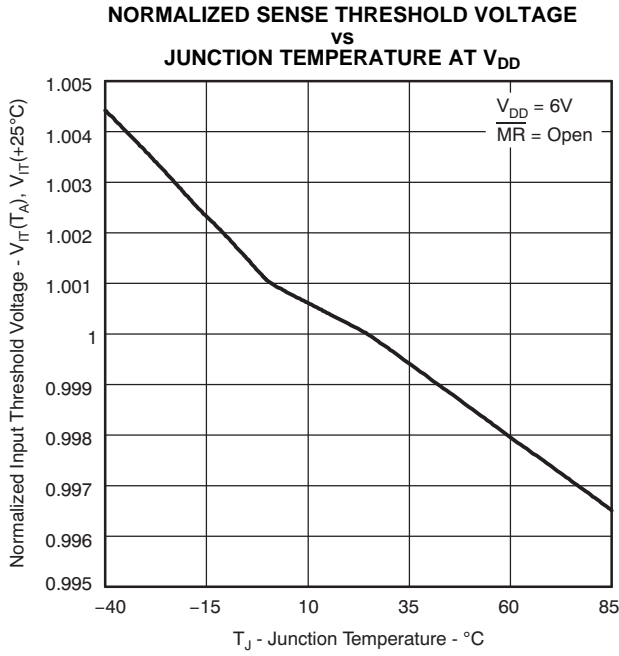

Figure 1.

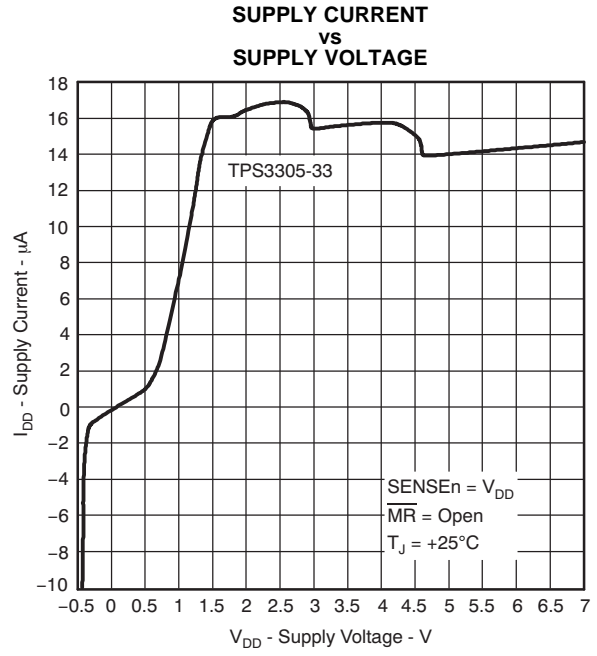

Figure 2.

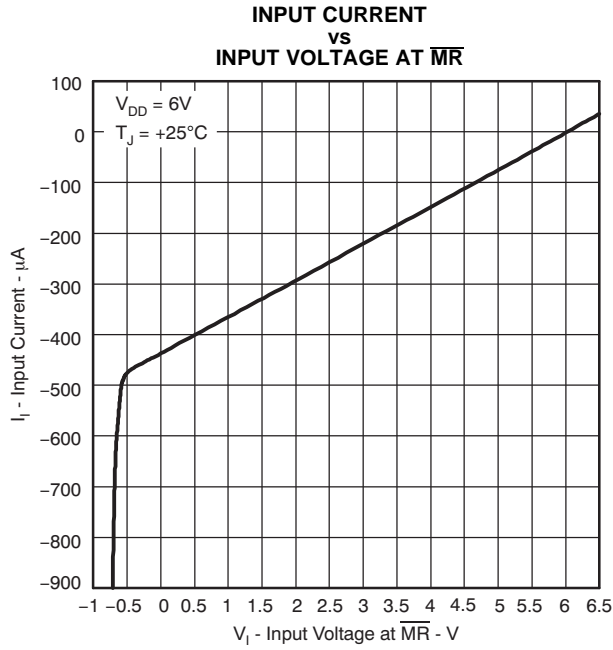

Figure 3.

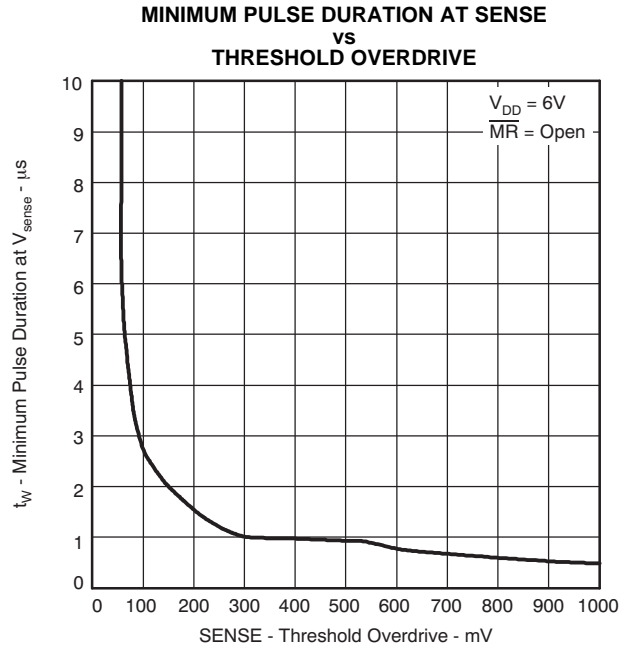
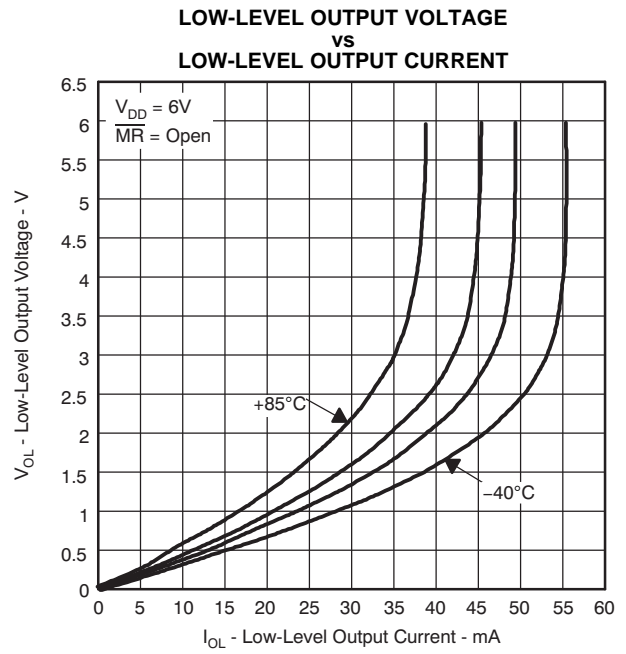
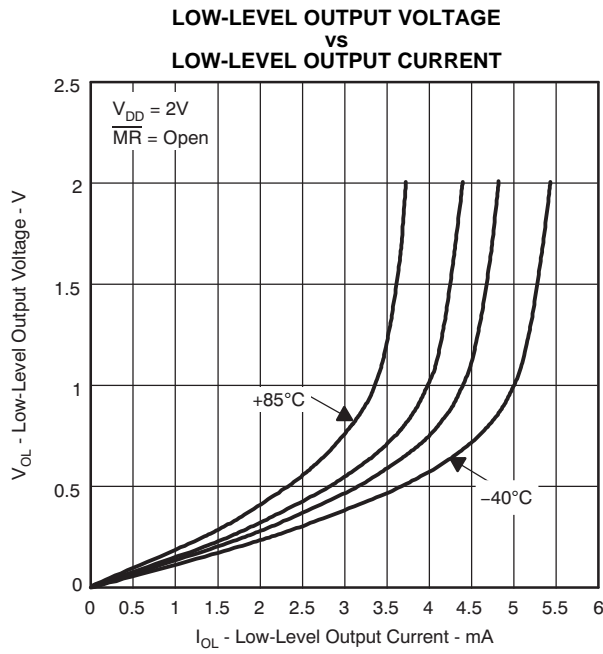
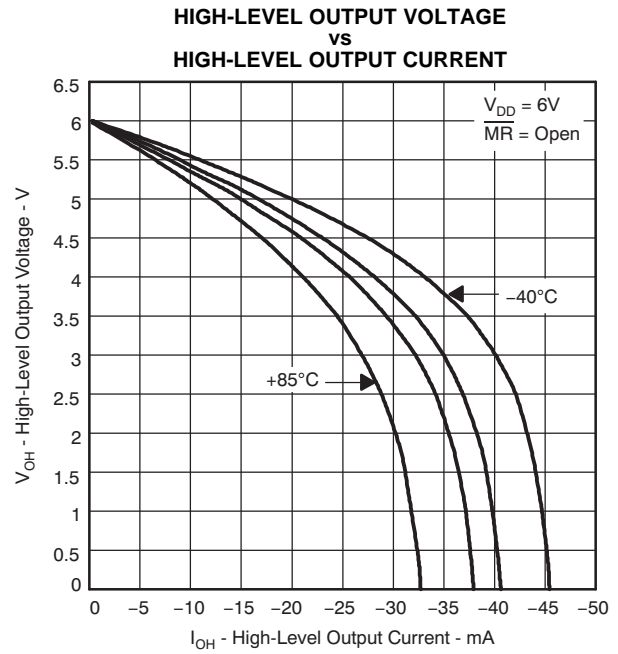
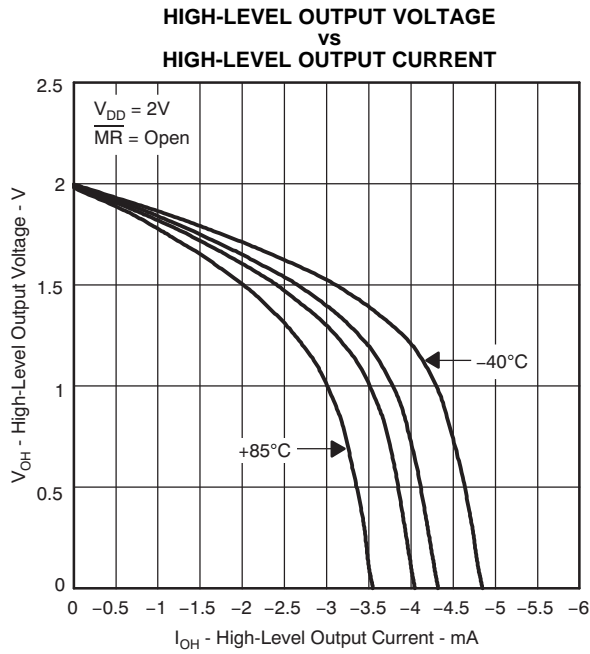

Figure 4.

TYPICAL CHARACTERISTICS (continued)



PACKAGING INFORMATION

Orderable Device	Status (1)	Package Type	Package Drawing	Pins	Package Qty	Eco Plan (2)	Lead/Ball Finish (6)	MSL Peak Temp (3)	Op Temp (°C)	Device Marking (4/5)	Samples
TPS3305-18D	ACTIVE	SOIC	D	8	75	Green (RoHS & no Sb/Br)	CU NIPDAU	Level-1-260C-UNLIM	-40 to 85	30518	Samples
TPS3305-18DG4	ACTIVE	SOIC	D	8	75	Green (RoHS & no Sb/Br)	CU NIPDAU	Level-1-260C-UNLIM	-40 to 85	30518	Samples
TPS3305-18DGN	ACTIVE	MSOP-PowerPAD	DGN	8	80	Green (RoHS & no Sb/Br)	CU NIPDAU	Level-1-260C-UNLIM	-40 to 85	AAM	Samples
TPS3305-18DGNG4	ACTIVE	MSOP-PowerPAD	DGN	8	80	Green (RoHS & no Sb/Br)	CU NIPDAU	Level-1-260C-UNLIM	-40 to 85	AAM	Samples
TPS3305-18DGNR	ACTIVE	MSOP-PowerPAD	DGN	8	2500	Green (RoHS & no Sb/Br)	CU NIPDAU	Level-1-260C-UNLIM	-40 to 85	AAM	Samples
TPS3305-18DGNRG4	ACTIVE	MSOP-PowerPAD	DGN	8	2500	Green (RoHS & no Sb/Br)	CU NIPDAU	Level-1-260C-UNLIM	-40 to 85	AAM	Samples
TPS3305-18DR	ACTIVE	SOIC	D	8	2500	Green (RoHS & no Sb/Br)	CU NIPDAU	Level-1-260C-UNLIM	-40 to 85	30518	Samples
TPS3305-18DRG4	ACTIVE	SOIC	D	8	2500	Green (RoHS & no Sb/Br)	CU NIPDAU	Level-1-260C-UNLIM	-40 to 85	30518	Samples
TPS3305-25D	ACTIVE	SOIC	D	8	75	Green (RoHS & no Sb/Br)	CU NIPDAU	Level-1-260C-UNLIM	-40 to 85	30525	Samples
TPS3305-25DGN	ACTIVE	MSOP-PowerPAD	DGN	8	80	Green (RoHS & no Sb/Br)	CU NIPDAU	Level-1-260C-UNLIM	-40 to 85	AAN	Samples
TPS3305-25DGNR	ACTIVE	MSOP-PowerPAD	DGN	8	2500	Green (RoHS & no Sb/Br)	CU NIPDAU	Level-1-260C-UNLIM	-40 to 85	AAN	Samples
TPS3305-25DR	ACTIVE	SOIC	D	8	2500	Green (RoHS & no Sb/Br)	CU NIPDAU	Level-1-260C-UNLIM	-40 to 85	30525	Samples
TPS3305-33D	ACTIVE	SOIC	D	8	75	Green (RoHS & no Sb/Br)	CU NIPDAU	Level-1-260C-UNLIM	-40 to 85	30533	Samples
TPS3305-33DG4	ACTIVE	SOIC	D	8	75	Green (RoHS & no Sb/Br)	CU NIPDAU	Level-1-260C-UNLIM	-40 to 85	30533	Samples
TPS3305-33DGN	ACTIVE	MSOP-PowerPAD	DGN	8	80	Green (RoHS & no Sb/Br)	CU NIPDAU	Level-1-260C-UNLIM	-40 to 85	AAO	Samples
TPS3305-33DGNG4	ACTIVE	MSOP-PowerPAD	DGN	8	80	Green (RoHS & no Sb/Br)	CU NIPDAU	Level-1-260C-UNLIM	-40 to 85	AAO	Samples
TPS3305-33DGNR	ACTIVE	MSOP-PowerPAD	DGN	8	2500	Green (RoHS & no Sb/Br)	CU NIPDAU	Level-1-260C-UNLIM	-40 to 85	AAO	Samples

Orderable Device	Status (1)	Package Type	Package Drawing	Pins	Package Qty	Eco Plan (2)	Lead/Ball Finish (6)	MSL Peak Temp (3)	Op Temp (°C)	Device Marking (4/5)	Samples
TPS3305-33DGNRG4	ACTIVE	MSOP- PowerPAD	DGN	8	2500	Green (RoHS & no Sb/Br)	CU NIPDAU	Level-1-260C-UNLIM	-40 to 85	AAO	Samples
TPS3305-33DR	ACTIVE	SOIC	D	8	2500	Green (RoHS & no Sb/Br)	CU NIPDAU	Level-1-260C-UNLIM	-40 to 85	30533	Samples

(1) The marketing status values are defined as follows:

ACTIVE: Product device recommended for new designs.

LIFEBUY: TI has announced that the device will be discontinued, and a lifetime-buy period is in effect.

NRND: Not recommended for new designs. Device is in production to support existing customers, but TI does not recommend using this part in a new design.

PREVIEW: Device has been announced but is not in production. Samples may or may not be available.

OBSOLETE: TI has discontinued the production of the device.

(2) **RoHS:** TI defines "RoHS" to mean semiconductor products that are compliant with the current EU RoHS requirements for all 10 RoHS substances, including the requirement that RoHS substance do not exceed 0.1% by weight in homogeneous materials. Where designed to be soldered at high temperatures, "RoHS" products are suitable for use in specified lead-free processes. TI may reference these types of products as "Pb-Free".

RoHS Exempt: TI defines "RoHS Exempt" to mean products that contain lead but are compliant with EU RoHS pursuant to a specific EU RoHS exemption.

Green: TI defines "Green" to mean the content of Chlorine (Cl) and Bromine (Br) based flame retardants meet JS709B low halogen requirements of <=1000ppm threshold. Antimony trioxide based flame retardants must also meet the <=1000ppm threshold requirement.

(3) MSL, Peak Temp. - The Moisture Sensitivity Level rating according to the JEDEC industry standard classifications, and peak solder temperature.

(4) There may be additional marking, which relates to the logo, the lot trace code information, or the environmental category on the device.

(5) Multiple Device Markings will be inside parentheses. Only one Device Marking contained in parentheses and separated by a "~" will appear on a device. If a line is indented then it is a continuation of the previous line and the two combined represent the entire Device Marking for that device.

(6) Lead/Ball Finish - Orderable Devices may have multiple material finish options. Finish options are separated by a vertical ruled line. Lead/Ball Finish values may wrap to two lines if the finish value exceeds the maximum column width.

Important Information and Disclaimer: The information provided on this page represents TI's knowledge and belief as of the date that it is provided. TI bases its knowledge and belief on information provided by third parties, and makes no representation or warranty as to the accuracy of such information. Efforts are underway to better integrate information from third parties. TI has taken and continues to take reasonable steps to provide representative and accurate information but may not have conducted destructive testing or chemical analysis on incoming materials and chemicals. TI and TI suppliers consider certain information to be proprietary, and thus CAS numbers and other limited information may not be available for release.

In no event shall TI's liability arising out of such information exceed the total purchase price of the TI part(s) at issue in this document sold by TI to Customer on an annual basis.

TAPE AND REEL INFORMATION

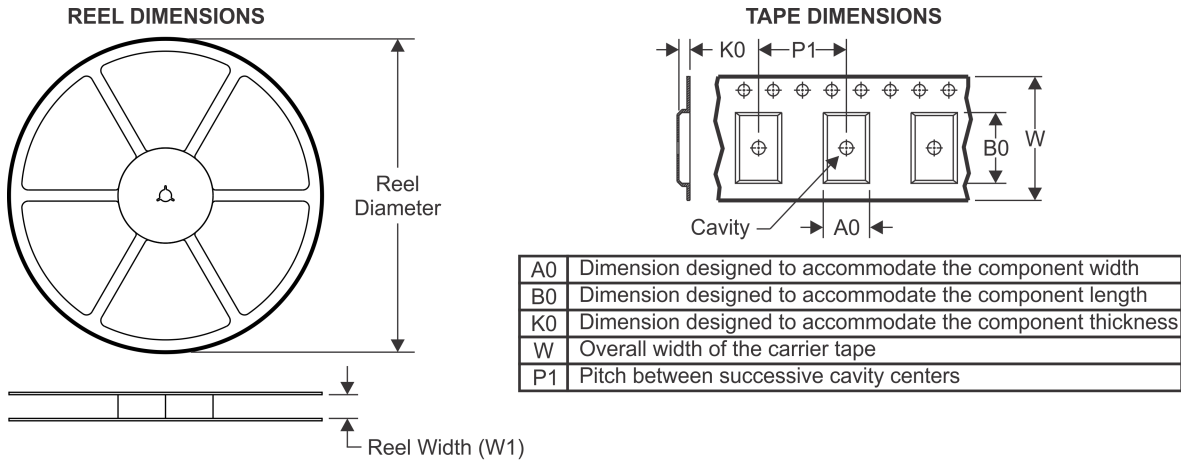

QUADRANT ASSIGNMENTS FOR PIN 1 ORIENTATION IN TAPE



*All dimensions are nominal

Device	Package Type	Package Drawing	Pins	SPQ	Reel Diameter (mm)	Reel Width W1 (mm)	A0 (mm)	B0 (mm)	K0 (mm)	P1 (mm)	W (mm)	Pin1 Quadrant
TPS3305-18DGNR	MSOP-Power PAD	DGN	8	2500	330.0	12.4	5.3	3.4	1.4	8.0	12.0	Q1
TPS3305-18DR	SOIC	D	8	2500	330.0	12.4	6.4	5.2	2.1	8.0	12.0	Q1
TPS3305-25DGNR	MSOP-Power PAD	DGN	8	2500	330.0	12.4	5.3	3.4	1.4	8.0	12.0	Q1
TPS3305-25DR	SOIC	D	8	2500	330.0	12.4	6.4	5.2	2.1	8.0	12.0	Q1
TPS3305-33DGNR	MSOP-Power PAD	DGN	8	2500	330.0	12.4	5.3	3.4	1.4	8.0	12.0	Q1
TPS3305-33DR	SOIC	D	8	2500	330.0	12.4	6.4	5.2	2.1	8.0	12.0	Q1

TAPE AND REEL BOX DIMENSIONS

*All dimensions are nominal

Device	Package Type	Package Drawing	Pins	SPQ	Length (mm)	Width (mm)	Height (mm)
TPS3305-18DGNR	MSOP-PowerPAD	DGN	8	2500	358.0	335.0	35.0
TPS3305-18DR	SOIC	D	8	2500	367.0	367.0	38.0
TPS3305-25DGNR	MSOP-PowerPAD	DGN	8	2500	358.0	335.0	35.0
TPS3305-25DR	SOIC	D	8	2500	367.0	367.0	38.0
TPS3305-33DGNR	MSOP-PowerPAD	DGN	8	2500	358.0	335.0	35.0
TPS3305-33DR	SOIC	D	8	2500	367.0	367.0	38.0

D (R-PDSO-G8)

PLASTIC SMALL OUTLINE



- NOTES:
- A. All linear dimensions are in inches (millimeters).
 - B. This drawing is subject to change without notice.
 - C. Body length does not include mold flash, protrusions, or gate burrs. Mold flash, protrusions, or gate burrs shall not exceed 0.006 (0,15) each side.
 - D. Body width does not include interlead flash. Interlead flash shall not exceed 0.017 (0,43) each side.
 - E. Reference JEDEC MS-012 variation AA.

D (R-PDSO-G8)

PLASTIC SMALL OUTLINE



- NOTES:
- A. All linear dimensions are in millimeters.
 - B. This drawing is subject to change without notice.
 - C. Publication IPC-7351 is recommended for alternate designs.
 - D. Laser cutting apertures with trapezoidal walls and also rounding corners will offer better paste release. Customers should contact their board assembly site for stencil design recommendations. Refer to IPC-7525 for other stencil recommendations.
 - E. Customers should contact their board fabrication site for solder mask tolerances between and around signal pads.

DGN (S-PDSO-G8)

PowerPAD™ PLASTIC SMALL OUTLINE

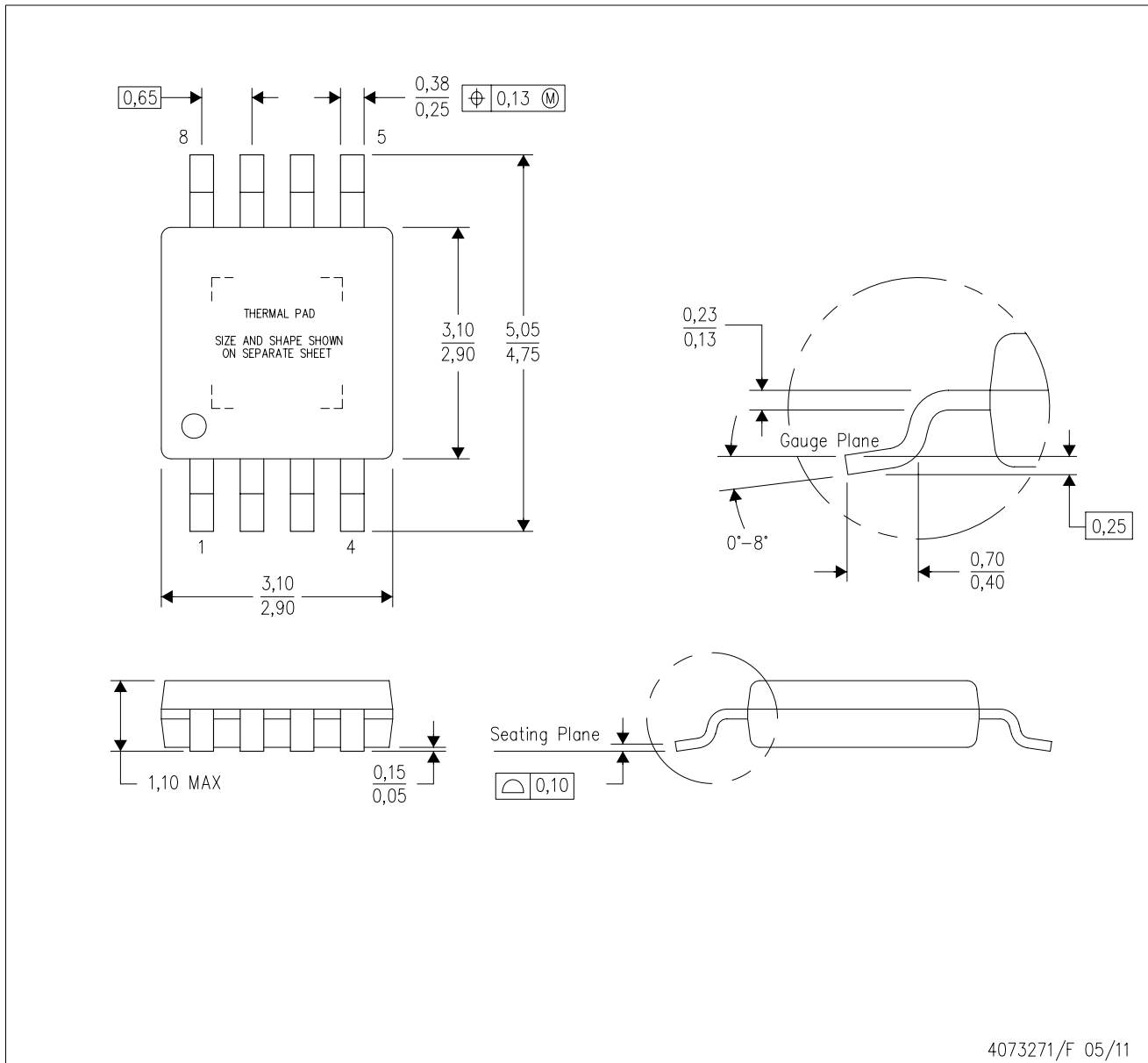

- NOTES:
- All linear dimensions are in millimeters.
 - This drawing is subject to change without notice.
 - Body dimensions do not include mold flash or protrusion.
 - This package is designed to be soldered to a thermal pad on the board. Refer to Technical Brief, PowerPad Thermally Enhanced Package, Texas Instruments Literature No. SLMA002 for information regarding recommended board layout. This document is available at www.ti.com <<http://www.ti.com>>.
 - See the additional figure in the Product Data Sheet for details regarding the exposed thermal pad features and dimensions.
 - Falls within JEDEC MO-187 variation AA-T

PowerPAD is a trademark of Texas Instruments.

DGN (S-PDSO-G8)

PowerPAD™ PLASTIC SMALL OUTLINE

THERMAL INFORMATION

This PowerPAD™ package incorporates an exposed thermal pad that is designed to be attached to a printed circuit board (PCB). The thermal pad must be soldered directly to the PCB. After soldering, the PCB can be used as a heatsink. In addition, through the use of thermal vias, the thermal pad can be attached directly to the appropriate copper plane shown in the electrical schematic for the device, or alternatively, can be attached to a special heatsink structure designed into the PCB. This design optimizes the heat transfer from the integrated circuit (IC).

For additional information on the PowerPAD package and how to take advantage of its heat dissipating abilities, refer to Technical Brief, PowerPAD Thermally Enhanced Package, Texas Instruments Literature No. SLMA002 and Application Brief, PowerPAD Made Easy, Texas Instruments Literature No. SLMA004. Both documents are available at www.ti.com.

The exposed thermal pad dimensions for this package are shown in the following illustration.

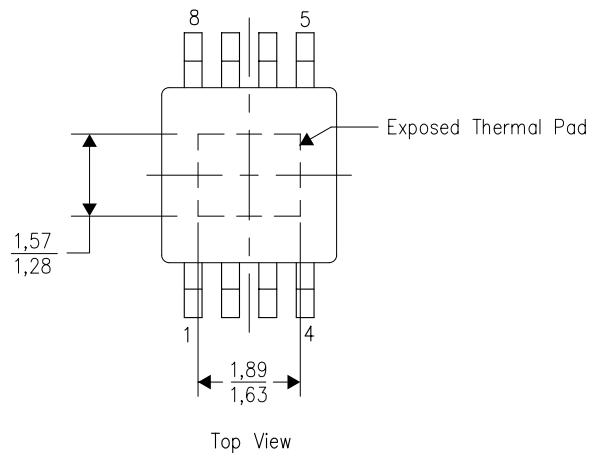

Exposed Thermal Pad Dimensions

4206323-2/1 12/11

NOTE: All linear dimensions are in millimeters

PowerPAD is a trademark of Texas Instruments

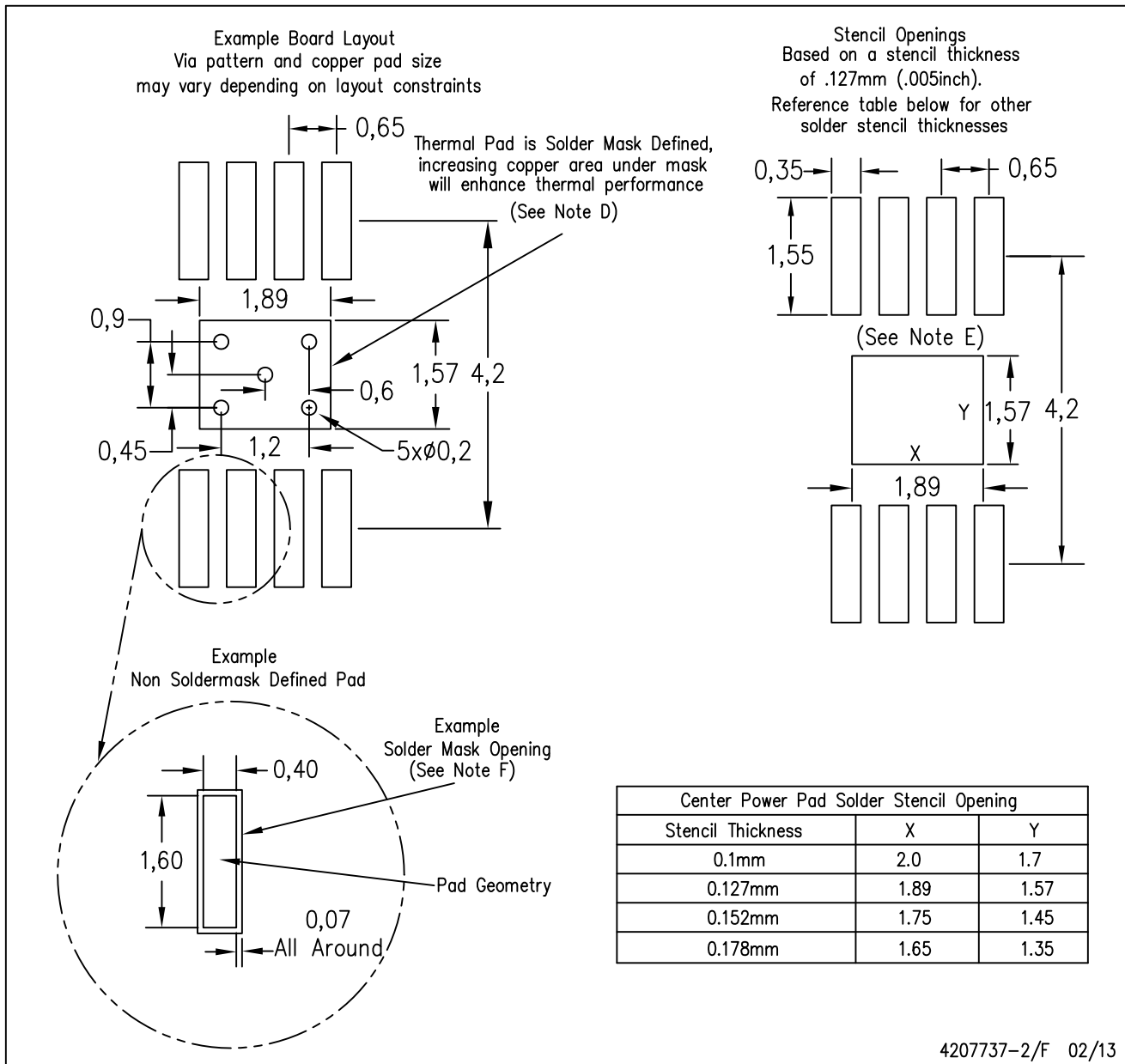

- NOTES:
- A. All linear dimensions are in millimeters.
 - B. This drawing is subject to change without notice.
 - C. Customers should place a note on the circuit board fabrication drawing not to alter the center solder mask defined pad.
 - D. This package is designed to be soldered to a thermal pad on the board. Refer to Technical Brief, PowerPad Thermally Enhanced Package, Texas Instruments Literature No. SLMA002, SLMA004, and also the Product Data Sheets for specific thermal information, via requirements, and recommended board layout. These documents are available at www.ti.com <<http://www.ti.com>>.
 - E. Laser cutting apertures with trapezoidal walls and also rounding corners will offer better paste release. Customers should contact their board assembly site for stencil design recommendations. Example stencil design based on a 50% volumetric metal load solder paste. Refer to IPC-7525 for other stencil recommendations.
 - F. Customers should contact their board fabrication site for solder mask tolerances between and around signal pads.

PowerPAD is a trademark of Texas Instruments

IMPORTANT NOTICE

Texas Instruments Incorporated (TI) reserves the right to make corrections, enhancements, improvements and other changes to its semiconductor products and services per JESD46, latest issue, and to discontinue any product or service per JESD48, latest issue. Buyers should obtain the latest relevant information before placing orders and should verify that such information is current and complete.

TI's published terms of sale for semiconductor products (<http://www.ti.com/sc/docs/stdterms.htm>) apply to the sale of packaged integrated circuit products that TI has qualified and released to market. Additional terms may apply to the use or sale of other types of TI products and services.

Reproduction of significant portions of TI information in TI data sheets is permissible only if reproduction is without alteration and is accompanied by all associated warranties, conditions, limitations, and notices. TI is not responsible or liable for such reproduced documentation. Information of third parties may be subject to additional restrictions. Resale of TI products or services with statements different from or beyond the parameters stated by TI for that product or service voids all express and any implied warranties for the associated TI product or service and is an unfair and deceptive business practice. TI is not responsible or liable for any such statements.

Buyers and others who are developing systems that incorporate TI products (collectively, "Designers") understand and agree that Designers remain responsible for using their independent analysis, evaluation and judgment in designing their applications and that Designers have full and exclusive responsibility to assure the safety of Designers' applications and compliance of their applications (and of all TI products used in or for Designers' applications) with all applicable regulations, laws and other applicable requirements. Designer represents that, with respect to their applications, Designer has all the necessary expertise to create and implement safeguards that (1) anticipate dangerous consequences of failures, (2) monitor failures and their consequences, and (3) lessen the likelihood of failures that might cause harm and take appropriate actions. Designer agrees that prior to using or distributing any applications that include TI products, Designer will thoroughly test such applications and the functionality of such TI products as used in such applications.

TI's provision of technical, application or other design advice, quality characterization, reliability data or other services or information, including, but not limited to, reference designs and materials relating to evaluation modules, (collectively, "TI Resources") are intended to assist designers who are developing applications that incorporate TI products; by downloading, accessing or using TI Resources in any way, Designer (individually or, if Designer is acting on behalf of a company, Designer's company) agrees to use any particular TI Resource solely for this purpose and subject to the terms of this Notice.

TI's provision of TI Resources does not expand or otherwise alter TI's applicable published warranties or warranty disclaimers for TI products, and no additional obligations or liabilities arise from TI providing such TI Resources. TI reserves the right to make corrections, enhancements, improvements and other changes to its TI Resources. TI has not conducted any testing other than that specifically described in the published documentation for a particular TI Resource.

Designer is authorized to use, copy and modify any individual TI Resource only in connection with the development of applications that include the TI product(s) identified in such TI Resource. NO OTHER LICENSE, EXPRESS OR IMPLIED, BY ESTOPPEL OR OTHERWISE TO ANY OTHER TI INTELLECTUAL PROPERTY RIGHT, AND NO LICENSE TO ANY TECHNOLOGY OR INTELLECTUAL PROPERTY RIGHT OF TI OR ANY THIRD PARTY IS GRANTED HEREIN, including but not limited to any patent right, copyright, mask work right, or other intellectual property right relating to any combination, machine, or process in which TI products or services are used. Information regarding or referencing third-party products or services does not constitute a license to use such products or services, or a warranty or endorsement thereof. Use of TI Resources may require a license from a third party under the patents or other intellectual property of the third party, or a license from TI under the patents or other intellectual property of TI.

TI RESOURCES ARE PROVIDED "AS IS" AND WITH ALL FAULTS. TI DISCLAIMS ALL OTHER WARRANTIES OR REPRESENTATIONS, EXPRESS OR IMPLIED, REGARDING RESOURCES OR USE THEREOF, INCLUDING BUT NOT LIMITED TO ACCURACY OR COMPLETENESS, TITLE, ANY EPIDEMIC FAILURE WARRANTY AND ANY IMPLIED WARRANTIES OF MERCHANTABILITY, FITNESS FOR A PARTICULAR PURPOSE, AND NON-INFRINGEMENT OF ANY THIRD PARTY INTELLECTUAL PROPERTY RIGHTS. TI SHALL NOT BE LIABLE FOR AND SHALL NOT DEFEND OR INDEMNIFY DESIGNER AGAINST ANY CLAIM, INCLUDING BUT NOT LIMITED TO ANY INFRINGEMENT CLAIM THAT RELATES TO OR IS BASED ON ANY COMBINATION OF PRODUCTS EVEN IF DESCRIBED IN TI RESOURCES OR OTHERWISE. IN NO EVENT SHALL TI BE LIABLE FOR ANY ACTUAL, DIRECT, SPECIAL, COLLATERAL, INDIRECT, PUNITIVE, INCIDENTAL, CONSEQUENTIAL OR EXEMPLARY DAMAGES IN CONNECTION WITH OR ARISING OUT OF TI RESOURCES OR USE THEREOF, AND REGARDLESS OF WHETHER TI HAS BEEN ADVISED OF THE POSSIBILITY OF SUCH DAMAGES.

Unless TI has explicitly designated an individual product as meeting the requirements of a particular industry standard (e.g., ISO/TS 16949 and ISO 26262), TI is not responsible for any failure to meet such industry standard requirements.

Where TI specifically promotes products as facilitating functional safety or as compliant with industry functional safety standards, such products are intended to help enable customers to design and create their own applications that meet applicable functional safety standards and requirements. Using products in an application does not by itself establish any safety features in the application. Designers must ensure compliance with safety-related requirements and standards applicable to their applications. Designer may not use any TI products in life-critical medical equipment unless authorized officers of the parties have executed a special contract specifically governing such use. Life-critical medical equipment is medical equipment where failure of such equipment would cause serious bodily injury or death (e.g., life support, pacemakers, defibrillators, heart pumps, neurostimulators, and implantables). Such equipment includes, without limitation, all medical devices identified by the U.S. Food and Drug Administration as Class III devices and equivalent classifications outside the U.S.

TI may expressly designate certain products as completing a particular qualification (e.g., Q100, Military Grade, or Enhanced Product). Designers agree that it has the necessary expertise to select the product with the appropriate qualification designation for their applications and that proper product selection is at Designers' own risk. Designers are solely responsible for compliance with all legal and regulatory requirements in connection with such selection.

Designer will fully indemnify TI and its representatives against any damages, costs, losses, and/or liabilities arising out of Designer's non-compliance with the terms and provisions of this Notice.