

Thick Film Chip Resistors

RC Series



FEATURES

- Extremely Thin and Light
- Highly Reliable Multilayer Electrode Construction
- Compatible with all Soldering Process
- Highly Stable in Auto-Placement Surface Mounting Applications
- Barrier Layer End Termination
- Zero Ohm Jumper is Available
- Available in 8mm Tape & Reel per EIA RS481

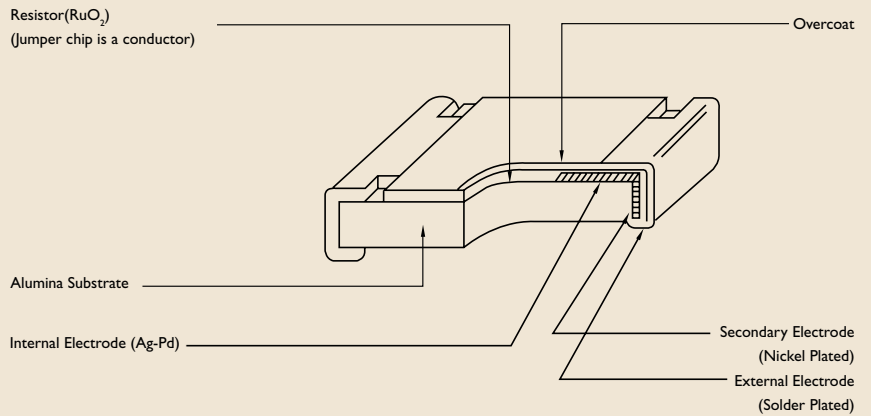

DIMENSIONS

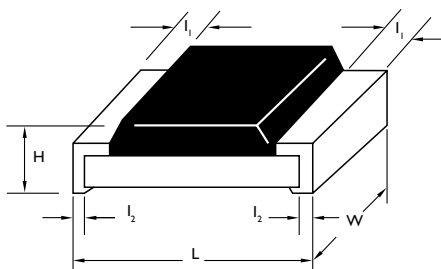

Unit : mm

STYLE	L	W	H	l_1	l_2
RC0201	0.60±0.10	0.30±0.05	0.25±0.05	0.15±0.10	0.15±0.10
RC0402	1.00±0.10	0.50±0.05	0.35±0.05	0.20±0.10	0.25±0.10
RC0603	1.60±0.10	0.80±0.10	0.45±0.10	0.25±0.15	0.25±0.15
RC0805	2.00±0.10	1.25±0.10	0.50±0.10	0.35±0.20	0.35±0.20
RC1206	3.10±0.10	1.60±0.10	0.55±0.10	0.45±0.20	0.40±0.20
RC1210	3.10±0.10	2.60±0.15	0.55±0.10	0.50±0.20	0.50±0.20
RC2010	5.00±0.10	2.50±0.15	0.55±0.10	0.60±0.20	0.50±0.20
RC2512	6.35±0.10	3.20±0.15	0.55±0.10	0.60±0.20	0.50±0.20

Note :

ELECTRICAL CHARACTERISTICS

STYLE	RC0201	RC0402	RC0603	RC0805	RC1206	RC1210	RC2010	RC2512
Power Rating @ 70°C	1/20W	1/16W	1/10W	1/8W	1/4W	1/3W	3/4W	1W
Operating Temp. Range	-55°C ~ +125°C							
Maximum Working Voltage	25V	50V	50V	150V	200V	200V	200V	200V
Maximum Overload Voltage	50V	100V	100V	300V	400V	400V	400V	400V
Dielectric Withstand Voltage	50V	100V	100V	300V	500V	500V	500V	500V
Resistance Range								
E24 Tol. ±2%, ±5%	10Ω ~ 1MΩ	2Ω ~ 3.3MΩ	1Ω ~ 22MΩ					
E96 Tol. ±0.5%, ±1%	100Ω ~ 2.2MΩ		100Ω ~ 2.2MΩ					
Zero Ohm Jumper<(0.05Ω)								
TCR ±100ppm/°C	–	–	10Ω ~ 1MΩ					
±200ppm/°C	10Ω ~ 1MΩ	10Ω ~ 3.3MΩ	1Ω ~ 10Ω, >1MΩ					
±400ppm/°C	–	2Ω ~ 10Ω	–					
Jumper Criteria								
Rated Current (A)	0.5	1.0	1.0	2.0	2.0	2.0	2.0	2.0
Maximum Current (A) @<1sec	1.0	2.0	2.0	5.0	10.0	10.0	10.0	10.0

ENVIRONMENTAL CHARACTERISTICS

PERFORMANCE TEST	TEST METHOD		1% TOL.	5% TOL.
Temperature Coefficient	MIL-STD-202F, Method 304	- 55°C to +125°C		by Type
Thermal Shock	MIL-STD-202F, Method 107	5 Cycles, -55°C to +125°C (Step by Step 2 min.)	±(0.5%+0.05Ω)	±(1%+0.05Ω)
Low Temperature Operation	MIL-R-55342D, Para.4.7.4	One Hour at - 65°C Followed by 45 Minutes RCWV	±(0.5%+0.05Ω)	±(1%+0.05Ω)
Short Time Overload	MIL-R-55342D, Para.4.7.5	2.5 Times RCWV for 5 Seconds	±(1%+0.05Ω)	±(2%+0.05Ω)
Insulation Resistance	MIL-STD-202F, Method 302	RCOV for 1 Minute		>10GΩ
Dielectric Withstand Voltage	MIL-STD-202F, Method 301	R.M.S. for 1 Minute		by Type
Resistance to Soldering Heat	MIL-STD-202F, Method 210C	Soldered to Test Board at 260°C for 10 Seconds	±(0.5%+0.05Ω)	±(1%+0.05Ω)
Moisture Resistance	MIL-STD-202F, Method 106F	42 Cycles.Total 1000 Hours	±(0.5%+0.05Ω)	±(2%+0.05Ω)
Life	MIL-STD-202F, Method 108A	1000 Hours at 70°C RCWV Intermittent	±(1%+0.05Ω)	±(3%+0.05Ω)
Solderability	MIL-STD-202F, Method 208G	230°C for 5 Seconds		>95% Coverage
Bending Strength	JIS-C-5202, Para.6.1.4, Unit Mounted in Center of 90mm Board Length, Deflected 5mm (power chip 2mm) in Either Direction for 5 Seconds		±(1%+0.05Ω)	±(1%+0.05Ω)