



## MASTER INSTRUMENT CORPORATION

**SINGLE-PHASE BRIDGE RECTIFIER**  
**2W005M THRU 2W10M**  
**RC201 THRU RC207**

**VOLTAGE RANGE** 50 to 1000 Volts  
**CURRENT** 1.5 Amperes

### FEATURES

- l Low cost
- l This series is UL recognized under component index, file number E127707
- l High forward surge current capability
- l Ideal for printed circuit board
- l High temperature soldering guaranteed: 260°C/10 second, 0.375"(9.5mm) lead length at 5 lbs. (2.3kg) tension.

### MECHANICAL DATA

- l Case: Molded plastic body
- l Terminal: Lead solderable per MIL-STD-202E method 208C.
- l Polarity: Polarity symbols molded on case
- l Mounting position: Any
- l Weight: 0.05ounce, 1.42grams

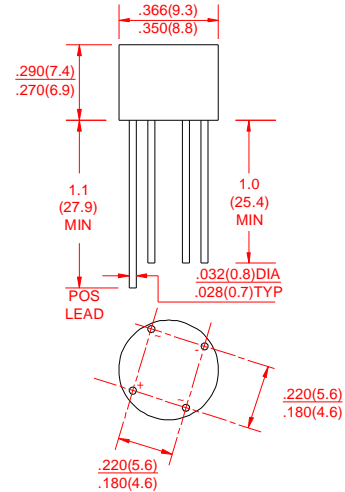

Dimensions in inches and (millimeters)

### MAXIMUM RATINGS AND ELECTRICAL CHARACTERISTICS

Ratings at 25°C ambient temperature unless otherwise specified.  
 Single phase, half wave, 60Hz, resistive or inductive load.  
 For capacitive load derate current by 20%.

	SYMBOLS	2W005M RC201	2W01M RC202	2W02M RC203	2W04M RC204	2W06M RC205	2W08M RC206	2W10M RC207	UNITS
Maximum Repetitive Peak Reverse Voltage	$V_{RRM}$	50	100	200	400	600	800	1000	Volts
Maximum RMS Voltage	$V_{RMS}$	35	70	140	280	420	560	700	Volts
Maximum DC Blocking Voltage	$V_{DC}$	50	100	200	400	600	800	1000	Volts
Maximum Average Forward Rectified Output Current, at $T_A=25^\circ\text{C}$	$I_{(AV)}$	1.5							Amps
Peak Forward Surge Current 8.3ms single half sine-wave superimposed on rated load (JEDEC Method)	$I_{FSM}$	50							Amps
Rating for Fusing( $t < 8.3\text{ms}$ )	$I^2T$	10							$\text{A}^2\text{S}$
Maximum Instantaneous Forward Voltage at 1.0A	$V_F$	1.0							Volts
Maximum DC Reverse Current at rated DC blocking voltage	$T_A=25^\circ\text{C}$	5.0							$\mu\text{Amps}$
	$T_A=100^\circ\text{C}$	0.5							mAmps
Typical Junction Capacitance(Note 1)	$C_J$	15							$\text{pF}$
Typical Thermal Resistance(Note 2)	$R_{\theta JA}$	40							$^\circ\text{C/W}$
Operating Temperature Range	$T_J$	-55 to +150							$^\circ\text{C}$
Storage Temperature Range	$T_{STG}$	-55 to +150							$^\circ\text{C}$

#### NOTES:

1. Measured at 1.0MHz and applied reverse voltage of 4.0 volts.
2. Unit mounted on P.C. board with  $0.22" \times 0.22"$  (5.5 x 5.5mm) copper pads, 0.375"(9.5mm) lead length.



MASTER INSTRUMENT CORPORATION

**SINGLE-PHASE BRIDGE RECTIFIER**  
**2W005M THRU 2W10M**  
**RC201 THRU RC207**

**VOLTAGE RANGE 50 to 1000 Volts**  
**CURRENT 1.5 Amperes**

RATINGS AND CHARACTERISTIC CURVES 2W005M THRU 2W10M

FIG.1- DERATING CURVE FOR OUTPUT RECTIFIED CURRENT

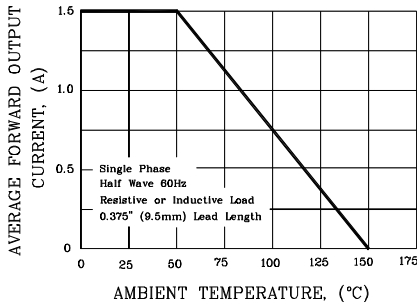

FIG.2- MAXIMUM NON-REPETITIVE PEAK FORWARD SURGE CURRENT PER ELEMENT

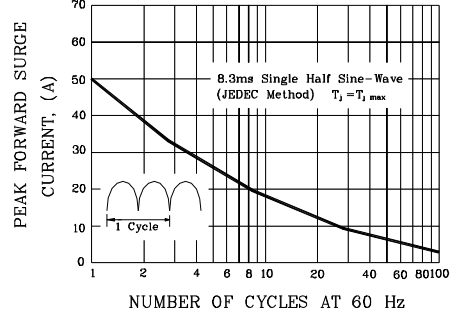

FIG.3- TYPICAL FORWARD CHARACTERISTICS PER BRIDGE ELEMENT

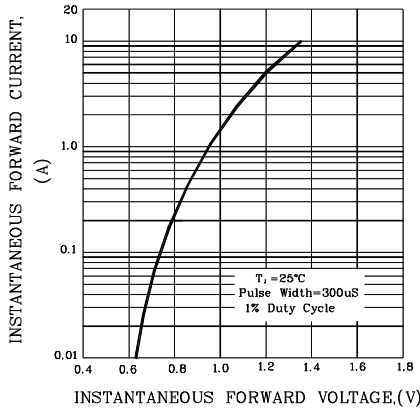

FIG.4- TYPICAL REVERSE CHARACTERISTICS PER BRIDGE ELEMENT

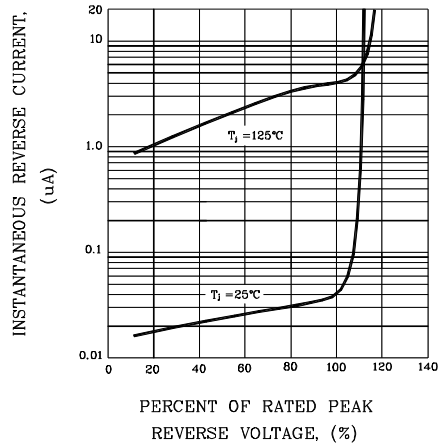

FIG.5- TYPICAL JUNCTION CAPACITANCE PER BRIDGE ELEMENT

